

HYDRAULIC NUT - UPPER COLLAR TYPE A20 (1500 BAR)

PART NUMBER	BOLT SIZE		HYDRAULIC AREA		INITIAL LOAD		NUT OD	NUT HEIGHT	MAX STROKE
	Inch	Metric	mm ²	in ²	kN	tons f			
UCA20-M331250	1-1/4	M33	1,797	2.8	270	27.0	79	53	6
UCA20-M361375	1-3/8	M36	2,203	3.4	331	33.2	86	53	6
UCA20-M391500	1-1/2	M39	2,512	3.9	377	37.8	91	55	6
UCA20-M421625	1-5/8	M42	2,925	4.5	439	44.0	97	55	6
UCA20-M451750	1-3/4	M45	3,346	5.2	502	50.4	106	55	6
UCA20-M481875	1-7/8	M48	3,534	5.5	530	53.2	110	70	8
UCA20-M522000	2	M52	4,536	7.0	680	68.3	120	72	8
UCA20-M562250	2-1/4	M56	5,372	8.3	806	80.9	129	72	8
UCA20-M642500	2-1/2	M64	6,856	10.6	1,028	103.2	147	74	9
UCA20-M682750	2-3/4	M68	7,948	12.3	1,192	119.6	157	74	9
UCA20-M763000	3	M76	9,499	14.7	1,425	143.0	173	80	11
UCA20-M803250	3-1/4	M80	11,442	17.7	1,717	172.2	187	84	11
UCA20-M903500	3-1/2	M90	13,383	20.7	2,008	201.4	204	90	11
UCA20-M953750	3-3/4	M95	14,653	22.7	2,198	220.5	213	95	11
UCA20-1004000	4	M100	17,197	26.7	2,580	258.8	231	103	16
UCA20-M1154500	4-1/2	M115	21,608	33.5	3,241	325.2	255	115	16
UCA20-M1255000	5	M125	26,389	40.9	3,959	397.2	278	125	16
UCA20-M1405500	5-1/2	M140	32,002	49.6	4,801	481.6	303	140	6
CA20-M1506000	6	M150	38,156	59.1	5,724	574.3	327	150	16
UCA-20M1807000	7	M180	52,993	82.1	7,950	797.6	383	180	16

NOTES

- This A20 range is designed to give an initial bolt stress of approx 20 tons f/sq inch.
- See the A15 range (on page 2) for nuts designed to give an initial bolt stress of 15 tons f/sq inch.
- Maximum initial load is generated at 1500 bar oil pressure.
- For hoses fittings and pumps see data sheets DS 601, DS 602, and DS 603.
- Sizes above M180 (7") can be built to order.
- Larger nuts can be tapped with a smaller thread size to give higher loads. Example thread a 2-1/4 inch nut with a 2 inch thread will give an initial load of 80.9 tons.
- Any number of nuts can be connected together for simultaneous operation.
- Service temperature -20°C to +80°C.

OPTIONS AVAILABLE

- Hexagon collar
- Twin hydraulic connections
- Special threads or thread forms
- Special designs for longer stroke, higher load, special threads



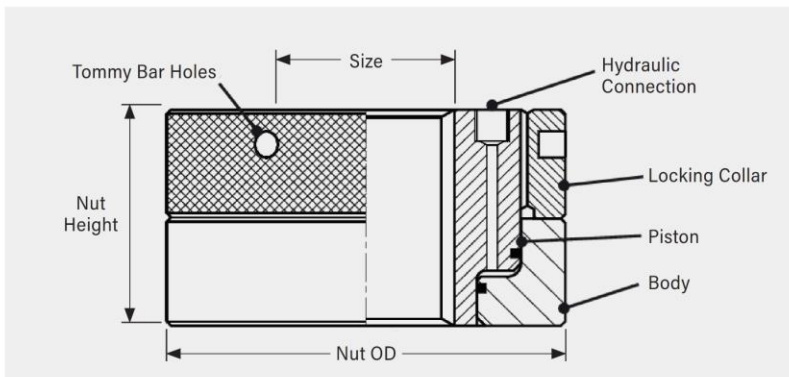

HYDRAULIC NUT - UPPER COLLAR TYPE A15 (1500 BAR)

PART NUMBER	BOLT SIZE		HYDRAULIC AREA		INITIAL LOAD		NUT OD	NUT HEIGHT	MAX STROKE
	Inch	Metric	mm ²	in ²	kN	tons f			
UCA15-M522000	2	M52	3,301	5.1	495	49.7	110	70	9
UCA15-M562250	2-1/4	M56	3,954	6.1	593	59.5	118	72	9
UCA15-M642500	2-1/2	M64	4,967	7.7	745	74.8	134	74	9
UCA15-M682750	2-3/4	M68	5,994	9.3	899	90.2	145	74	9
UCA15-M763000	3	M76	7,046	10.9	1,057	106.0	159	80	11
UCA15-M803250	3-1/4	M80	8,328	12.9	1,249	125.3	171	84	11
UCA15-M903500	3-1/2	M90	9,877	15.3	1,482	148.7	187	90	11
UCA15-M953750	3-3/4	M95	10,967	17.0	1,645	165.1	196	95	11
CA15-M1004000	4	M100	12,691	19.7	1,904	191.0	212	103	16
UCA15-M1154500	4-1/2	M115	16,157	25.0	2,424	243.2	234	115	16
UCA15-M1255000	5	M125	19,536	30.3	2,931	294.0	254	125	16
UCA15-M1405500	5-1/2	M140	23,974	37.2	3,596	360.8	277	140	16
CA15-M1506000	6	M150	28,452	44.1	4,268	428.2	299	150	16
UCA15-M1807000	7	M180	39,677	61.5	5,952	597.1	350	170	16

NOTES

- This A15 range is designed to give an initial bolt stress of approx 15 tons f/sq inch.
- See the A20 range (on page 1) for nuts designed to give an initial bolt stress of 20 tonsf/sq inch.
- Maximum initial load is generated at 1500 bar oil pressure.
- For hoses fittings and pumps see Data Sheets DS-601, DS-602, and DS-603.
- For sizes below M52 (2 inch) use A20 range (see page 1). Sizes above M180 (7") can be built to order.
- Larger nuts can be tapped with a smaller thread size to give higher loads. Example Thread a 2-1/4 inch nut with a 2 inch thread will give an initial load of 59.5 tons. Alternatively use A20 range (see Page 1).
- Any number of nuts can be connected together for simultaneous operation.
- Service temperature -20°C to +80°C.
- 9 - Due to continuous product development dimensions may change without notice.

OPTIONS AVAILABLE

- Hexagon collar
- Twin hydraulic connections
- Special threads or thread forms
- Special designs for longer stroke, higher load, special threads

HYTORC owns all content, copyrights, trademarks and patents in this document. © 2020 HYTORC. Any unauthorized use or distribution of any material from this document is strictly prohibited.

