

HYTORC®

Since 1968



7FA Gas Turbine Casing Tensioners *Operational and Maintenance Manual*

Job Number:

Date:

Copyright Statement & Disclaimer

This Health & Safety, Operating and Maintenance Manual has been prepared by the company, HYTORC. All of the material in this manual is the property of the company and is subject to copyright. No part of this manual may be copied or reproduced without the prior written consent of the company.

Please note that the scope of this document covers the safety, operation and maintenance instructions concerned with the equipment supplied ONLY. Safe handling, usage and storage of this equipment on customer applications and installations is the responsibility of the customer. This document should only be considered a part of the customer's wider procedure for installation of plant and therefore HYTORC cannot accept any responsibility for any actions arising as a result of misuse of this equipment.

The contents of this manual may periodically be subject to alteration. HYTORC reserves the right to alter or modify this manual without prior notification.

Further copies of this manual may be purchased from HYTORC.

Foreword

Thank you for purchasing or renting HYTORC Bolt Tensioning Equipment.

Before using the bolt tensioning equipment you are advised to study this operating manual carefully.

The bolt tensioning equipment has been designed to comply with the European Pressure Equipment Directive and is CE marked. However the pressures and forces involved with the use of this equipment are high and it is imperative that use users of the equipment read and understand the operating manual, paying particular attention to the safety information in Section 2.0.

Contents

Technical Information

European Pressure Equipment Directive

General Description

Health & Safety

Important Notice

Quick Connectors

Bolt Tensioning Tools

Operating Instructions

Introduction

Tool Description

Stroke Indicator

Tightening a Bolt

Loosening a Bolt

Maintenance & Storage

General Information

Storage

Maintenance

Specification

General Arrangement Drawings

Pressure Calculations

Oil Pressure vs Theoretical Tensioning Force Graph

Air Driven Pump

Section 1

Page 01

Page 01

Section 2

Page 01

Page 02

Page 02

Section 3

Page 01

Page 02

Page 02

Page 04

Page 18

Section 4

Page 01

Page 01

Page 01

Section 5

Page 01

Page 08

Page 09

Section 6

Section 1

Technical Information

European Pressure Equipment Directive

The HYTORC range of hydraulic bolt tensioning tools have been designed to operate at pressures up to 1500 bar with Group 2 liquid (hydraulic oil) and volume less than 10 litres.

This equipment falls into category 1 of the specified pressure volume thresholds. Under the regulations the equipment must therefore:-

- a) be safe
- b) meet the essential safety requirements covering design, manufacture and testing
- c) satisfy the appropriate conformity assessment procedure
- d) be accompanied by adequate instructions for use
- e) be marked to identify the manufacturer and CE marked

The hydraulic cylinder has been pressure tested at 10% above its maximum operating pressure and a test certificate has been issued.

General Description

The pressure equipment covered by this operating manual is a multi-stage hydraulic bolt tensioning tool. The tensioner comprises two axially-stacked interlocking load cells (each comprising a body, piston, inner/outer seal and reaction nut), a common central puller bar with ½" drive socket, a spring retraction mechanism and interconnecting bridge. The bridge incorporates a spring-loaded gear-driven nut rundown mechanism for convenience, also incorporating a ½" drive socket.

The load cells are pressurised via a radial manifold block, using a CEJN 116 high pressure nipple. Each load cell is fitted with hybrid composite plastic and rubber hydraulic seals. The user must ensure that the hoses and pumps utilised to pressurise the tool are suitable for compatibility with the bolt tensioners supplied, and also rated for safe usage at or above the tools maximum operating pressure. Where in doubt the operator must contact HYTORC for further information.

Within the tensioner, the upper and lower Hydraulic Load Cells are interlocked for simultaneous pressurisation and are supported by the Bridge. Both load cells engage a common puller bar, whose design has been configured in conjunction with the Bridge design to provide optimum engagement with the customer's application. Tensioning applications can be used with standard hex nuts, large width hex nuts, round nuts or special nuts. The correct tool must be selected in accordance with the application. The gear driven socket within the bridge has been designed to interface snugly with the across flats dimensions of hex nuts as supplied by the customer, and nut rundown following pressurisation is achieved by rotating the gear driven socket. This is performed via the ½" square drive socket located at the top of the gearbox. This gearbox and geared socket mechanism can also be utilised to unwind nuts during de-tensioning procedures.

Before handling check the unit weight in section 5. If it is less than 20kg then it can be handled manually. Larger tools should not be lifted by hand.

The different sizes of Multi Stage tools have different maximum strokes. Refer to the information in section 5 to confirm the maximum stroke of the model supplied. A visual indicator ring mounted near the top of the puller allows the operator to determine when this maximum stroke has been reached. Although the tensioner has been designed with a positive stop to prevent over-stroking, the tool should never be over-stroked beyond its maximum working pressure. Whenever the visual indicator ring can be seen protruding through the top of the tool, the operator should immediately shut-off the pump and reset the tool to zero stroke before tensioning/de-tensioning is resumed (see Section 3 for full instructions).

The tool features a spring-actuated piston return facility. The spring retraction system comprises heavy duty springs, which are contained within the spring cap. The spring system should not require attention during the working life of the tool. When the pressure within the tool is returned to zero the spring force will retract the pistons fully back into the outer bodies. As mentioned above, care should be taken not to stroke the tool beyond its maximum stroke.

The tool also features a safe failure mechanism. In the event that the fatigue life of the tool expires, it has been engineered to fail safely and remain in-situ upon the bolt, posing no threat to adjacent personnel or equipment.

The maximum tool pressure cycles is indicated with the tool technical data. A record of pressure cycles should be kept and the tool returned for puller replacement before reaching this limit. A cycle counter can be fitted to the tensioner, to assist with quantifying the number of cycles the tool has experienced.

The tensioner must not be modified by any type of machining and no attachment can be made to the tools by any form of welding or brazing.

The tensioner has been subjected to a one-off pressure test prior to despatch, and a test certificate has been issued to certify this. Please note that this is not the maximum operating pressure and it is strongly advised that the tool is NEVER operated above its maximum operating pressure. The tool does not require re-testing during its working life, even after fitting new sealing elements. If the user wishes to conduct a pressure test, the tensioner should be returned to the manufacturer's works for recertification.

Section 2

Health & Safety

Persons using hydraulic bolt tensioning tools must read and understand this section before starting to use the equipment. Your attention is particularly drawn to the instructions in RED on Page 2 and Page 5

Important Notice



THINK SAFETY

Thank you for purchasing or renting your hydraulic bolt tensioning equipment from **HYTORC**. Bolt tensioning tools are very powerful and capable of inducing very high bolt stresses. This equipment has been designed to give many years of safe tightening of bolted connections when used in accordance with these instructions.

Persons using hydraulic bolt tensioning tools must be properly trained in the correct use of the equipment and must also take adequate steps to ensure their own safety, and the Health and Safety of others working in the area where bolt tensioning operations are being performed. **HYTORC** will be pleased to quote for the provision of training courses either at its UK base or on site anywhere in the world.

Operators must read all of this instruction and maintenance manual before attempting to use the equipment. Do not use the equipment if you are not already an experienced user of hydraulic bolt tensioning tools or if you have not already received proper training. Your attention is particularly drawn to the notes in **RED**.

When tightening/loosening bolts using tensioners, extremely high loads are induced. If the bolt material is incorrectly specified or the bolt has been subjected to any damage, it is possible that the bolt may shear. This could also occur if the tool is incorrectly installed (i.e. if there is insufficient thread engagement between the tensioner and the bolt). In these scenarios the tool could be launched at high speed along the axis of the bolt. This is an extremely rare occurrence provided that procedures are followed correctly, however in the event of failure anyone standing in line with the axis of the bolt during the tensioning operation will suffer critical injury or even be killed. It is therefore essential that anyone operating this equipment is properly trained in its safe use and takes every precaution to ensure that nobody is allowed to stand, work or stray near to or into line with the axis of any bolt tensioning tool during the bolt tensioning operation.

Bolt tensioning tools are powerful and when using high pressure hydraulics it is essential that you are trained in the correct use of the equipment and adhere fully with the Health and Safety Instructions.

Quick Connectors



DO NOT pressurise the connectors when they are disconnected.

Check there is no pressure in the system before attempting to connect or disconnect the couplings.

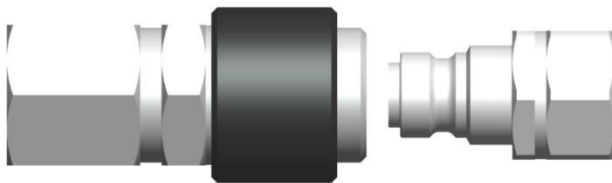
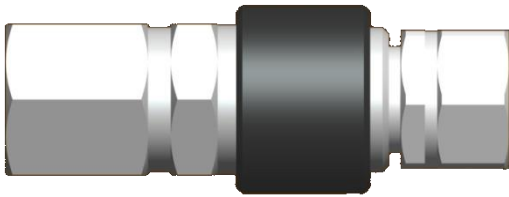

Bolt Tensioning Tools



DO NOT exceed the tools Maximum Working Pressure. (This information can be found in section 5)

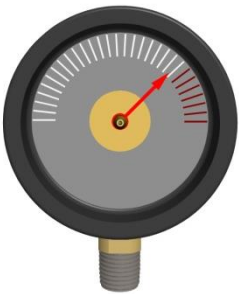

\leq Maximum

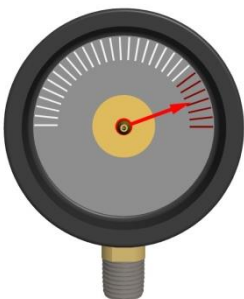

$>$ Maximum





DO NOT pressurise the bolt tensioning tool unless it is attached to a fully engaged bolt.

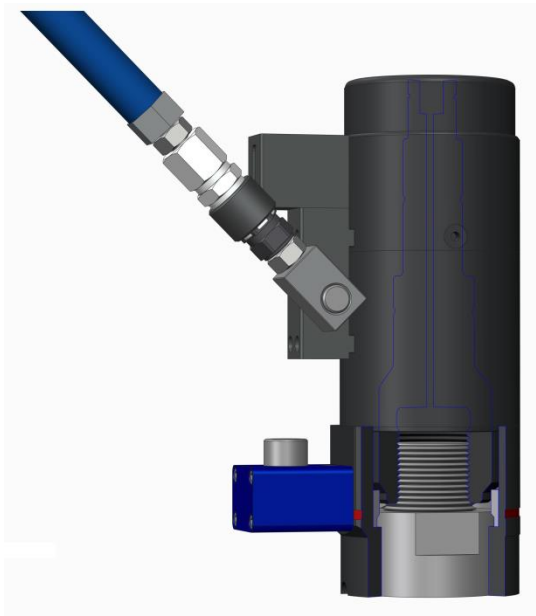
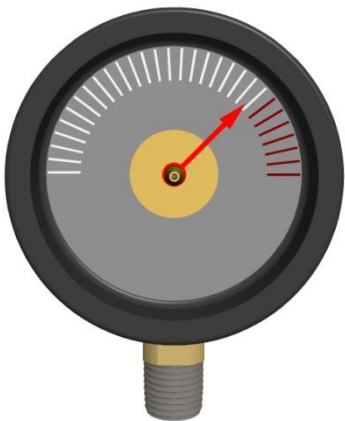
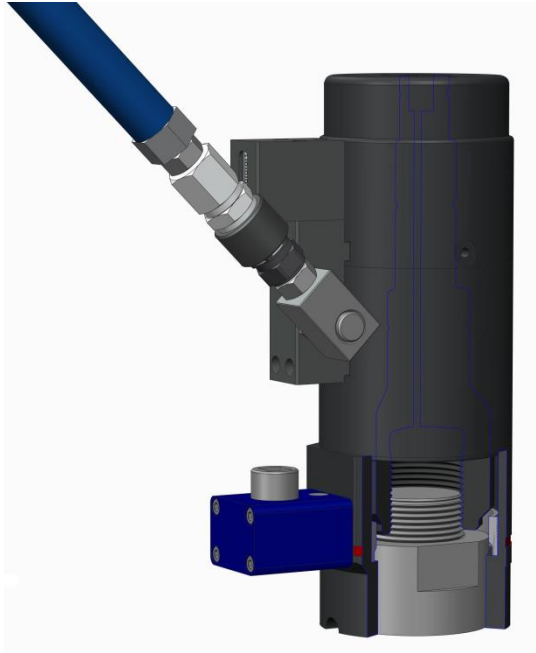
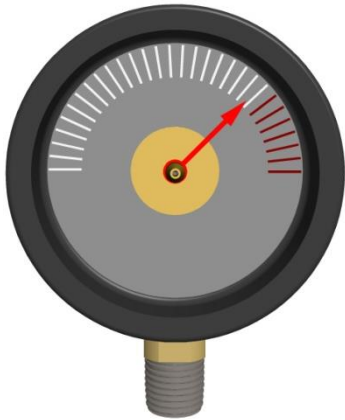



Bolt tensioning tools **MUST** always be used with a hydraulic pump which has a pressure limiting device. Always check that the pump stall pressure is set at or below the maximum working pressure for the tool being used.



Clear all personnel from the area where the bolt tensioning operation is to be performed. Position the pump a safe distance away from the bolt tensioning tools. Set up barriers and warning signs, or make other adequate arrangements to prevent unauthorised personnel from accidentally straying into the bolt tensioning area.



Ensure that nobody is allowed to stand near to a bolt tensioning tool during pressurisation. At no time should anyone allow any part of their body to be positioned over the bolt axis of a bolt tensioner whilst the pressure is rising or when it is pressurised.



Do not approach a bolt tensioning tool whilst it is being pressurised. Remember that a damaged bolt or tool is most likely to fail at this critical time. When the operating pressure has been reached, approach a pressurised bolt tensioning tool only for as long as is necessary to rotate the ring nut. Ensure that when rotating the nut you are well outside of the tensioners vertical axis.



Never leave a pressurised bolt tensioning tool unattended. Keep the bolt tensioning tools under pressure for the minimum time necessary to complete the bolt tightening operation.



Always ensure adequate PPE (Personal Protective Equipment) is worn by all personnel using bolt tensioning tools. SAFETY GLASSES and GLOVES are essential. OVERALLS and a HARD HAT are recommended.



The equipment supplied should only be used as intended (i.e. as a bolt tensioning tool). **DO NOT** use the tools as hydraulic jacks or for any other purpose.



Do not pick up or carry bolt tensioning tools using flexible hydraulic hoses as a handle.



Do not try to tighten a leaking hydraulic connection when it is under pressure. First release the pressure, then repair the leak.



NEVER touch a hydraulic hose under pressure or allow it to rest across any part of the body. Do not pressurise a hydraulic hose if any person is or is likely to come into contact with it during pressurisation. If it requires moving or repositioning, **ALWAYS** release the pressure beforehand.

Section 3

Operating Instructions

Introduction

A hydraulic bolt tensioning tool provides a quick and easy method for tightening large diameter bolts to high and accurate pre-loads. Unlike conventional methods, it does not use torque and does not require any forceful turning of the nut or bolt (as is the case using impact wrenches, flogging spanners or hydraulic torque wrenches). All of these methods have one common drawback: FRICTION. Overcoming thread friction and friction between the nut and the washer uses up over 80% of the torque energy applied to the nut or bolt, leaving less than 20% of the energy to produce useful tension in the shank of the bolt. Variations in this friction loss from bolt to bolt causes non-uniform tension in bolts that have been tightened to the same torque or impact wrench setting.

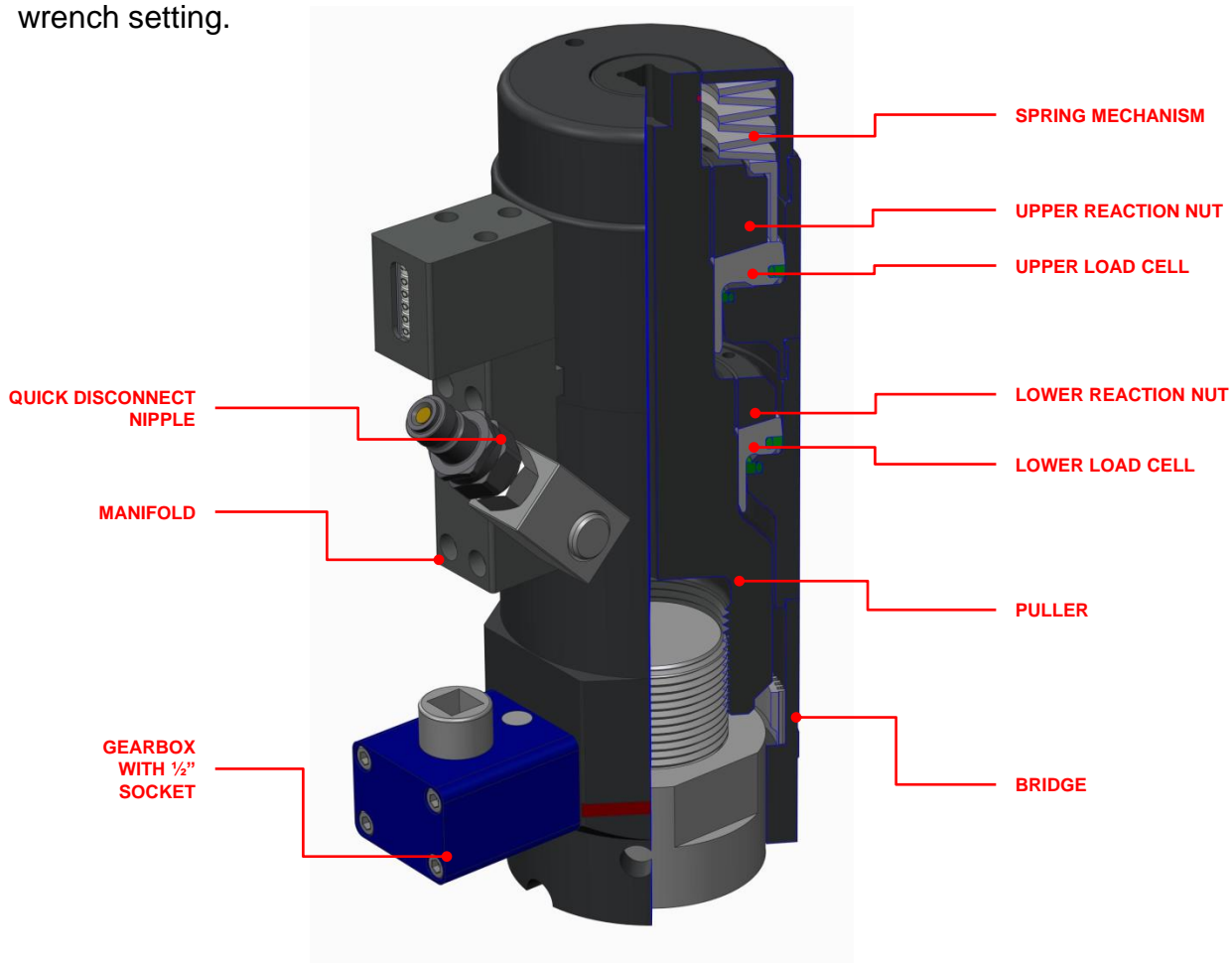

A hydraulic bolt tensioner is an annular jack which fits over the bolt and nut to be tightened. The jack pushes against the bolted joint and pulls on the end of the bolt, which typically needs to be at least one diameter longer to accommodate the bolt tensioning tool (although this varies according to the load and bolt material specified). Because the tensioner force produced is applied directly to the end of the bolt, a tension equal to the load generated by the tensioner is developed in the shank of the bolt. With the tool applying this tension, it is possible to turn the nut with zero torque until it is tight. The load applied by the tensioner is then relaxed and a known percentage (depending on the length of the bolt and its diameter) is retained within the bolt. This proportion of load retained is usually very high; thusly tensioning method offers significantly better efficiency as well as accuracy compared to other bolt tightening methods.

Bolt tensioning tools can be grouped to enable multiple bolts to be tightened simultaneously, to the same high and accurate pre-load. This is particularly useful when compressing gaskets in pipeline or pressure vessel flanged connections. The high load developed by the multiple bolt tensioning tools is evenly distributed around the joint causing the gasket to flow into the surface irregularities of the flange, resulting in a much better seal.

Flexible hoses with self sealing quick disconnect couplings are used to connect the bolt tensioning tools together to form a hydraulic ring main. The ring main and tensioning tools are usually pressurised using an air driven pump working from a compressed air supply, although hand pumps are also permissible.

Tool Description

The Turbine Closure Range has been engineered to provide maximum load capacity under minimal radial envelope conditions.

A multi-stage bolt tensioning tool comprises two axially-stacked interlocking load cells (each comprising a body, piston, inner/outer seal and reaction nut), a common central puller bar with ½” drive socket, a spring retraction mechanism and interconnecting bridge. The bridge incorporates a gear-driven nut rundown mechanism for convenience, also incorporating a ½” drive socket. The tensioner incorporates a mechanical anti-overstroke protection facility, and also features a maximum stroke indicator. The load cells are pressurised simultaneously via a radially mounted manifold block of vertical CEJN 116 nipple configuration.

The maximum operating pressure, maximum force and maximum stroke for the equipment are all listed in the Specification section (section 5).

Stroke Indicator

The diagram on the next page shows the stroke indicator. The operator is alerted that maximum stroke has been achieved by the indicator ring which is mounted in the shaft of the puller .

When the tool reaches maximum stroke; i.e. when this indicator is visible to the operator, the operator should stop the pump and tighten the nut. No further benefit is gained by increasing the pressure at maximum stroke as the bolt cannot be stretched any further.

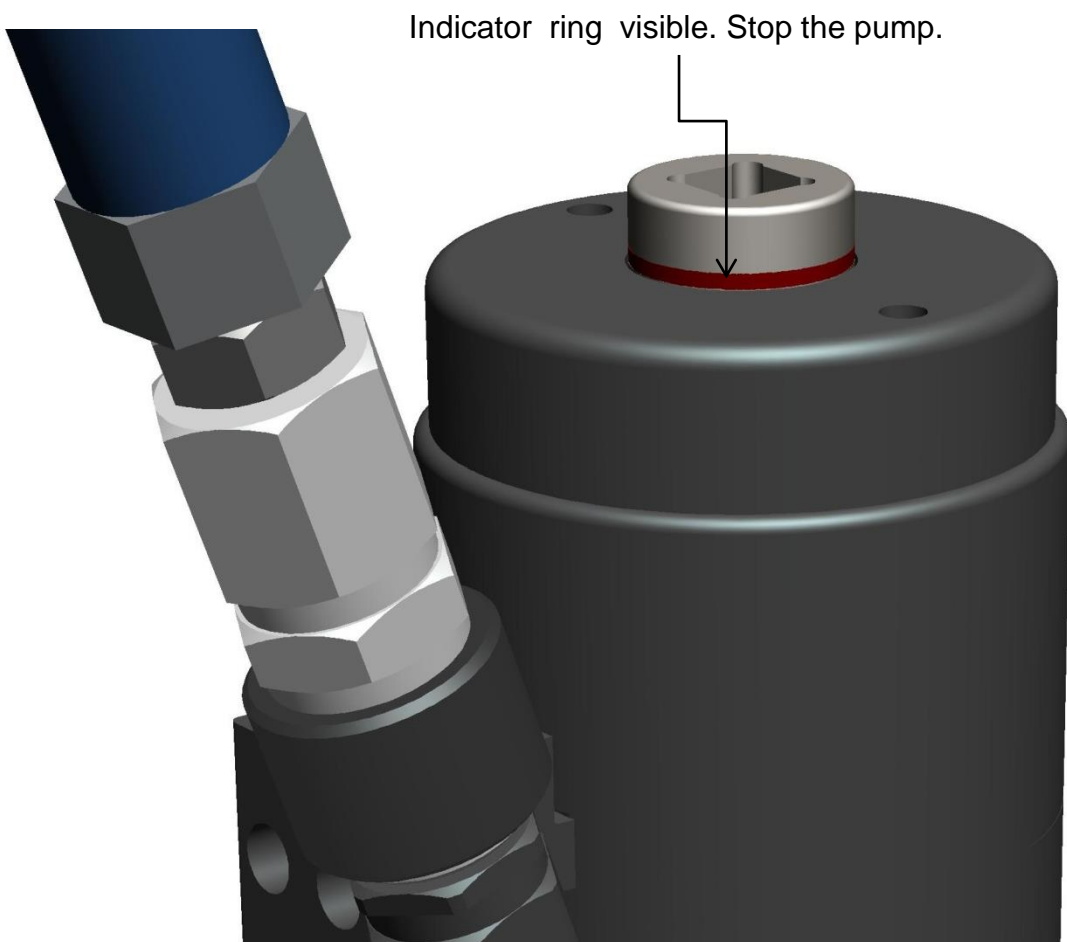
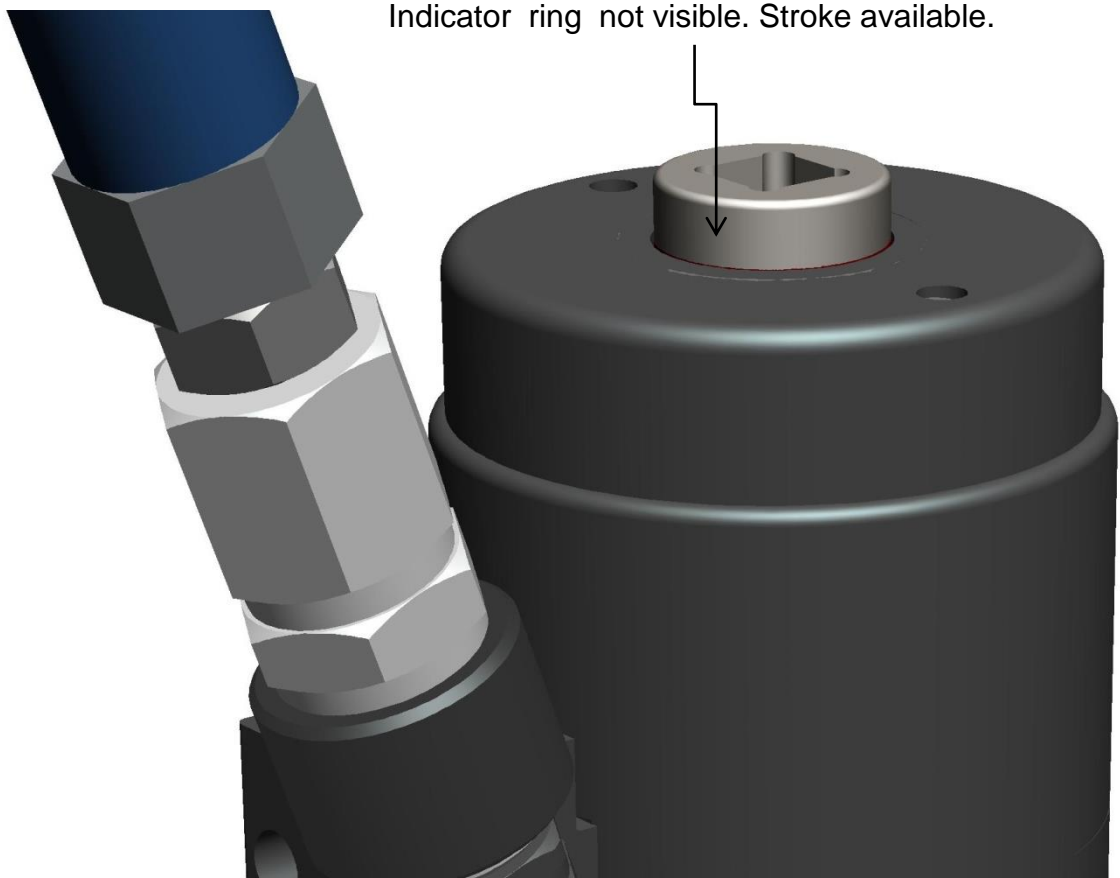

Step 1 – Tightening a Bolt

Before commencing the bolt tensioning operation read and comply with all of the Health & Safety Instructions in Section 2. Operators should also be familiar with the 'Important Information' literature in Sections 1 and 5.

Step 2 – Tightening a Bolt

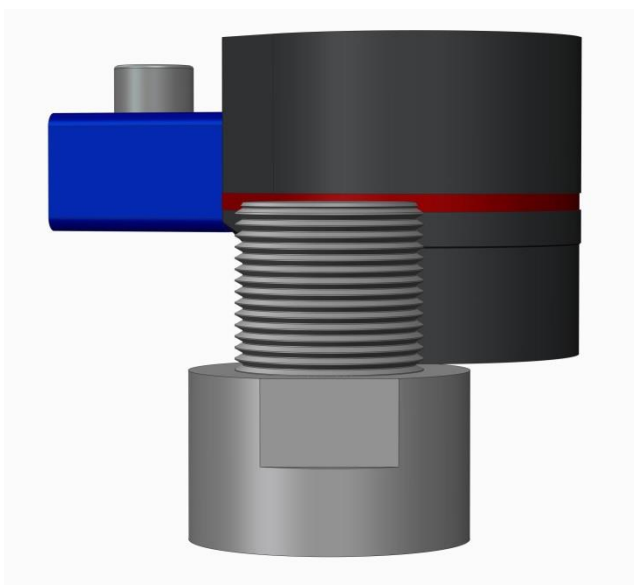

Ensure that sufficient bolt is protruding to engage the tensioner. The stud protrusion range is denoted by the red line on the outside of the Bridge Assembly, when it is positioned on top of the assembled nut. The stud protrusion must be within this band.

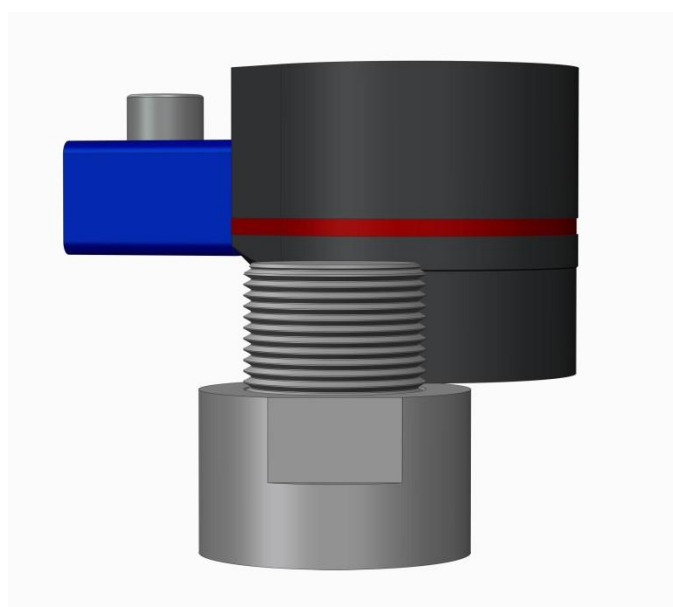

Either the stud protrusion is too short or the nut is too high up the bolt. Engagement with the Tensioner is insufficient – the bolt threads may strip and cause injury.

Step 3 – Tightening a Bolt

Position the Tensioner over the bolt to be tightened.



Step 4 – Tightening a Bolt

Engage the Puller with the bolt. A 1/2in Square Socket is provided in the top of the Puller Bar so that the Tensioner orientation can be maintained whilst the Puller engages the bolt.

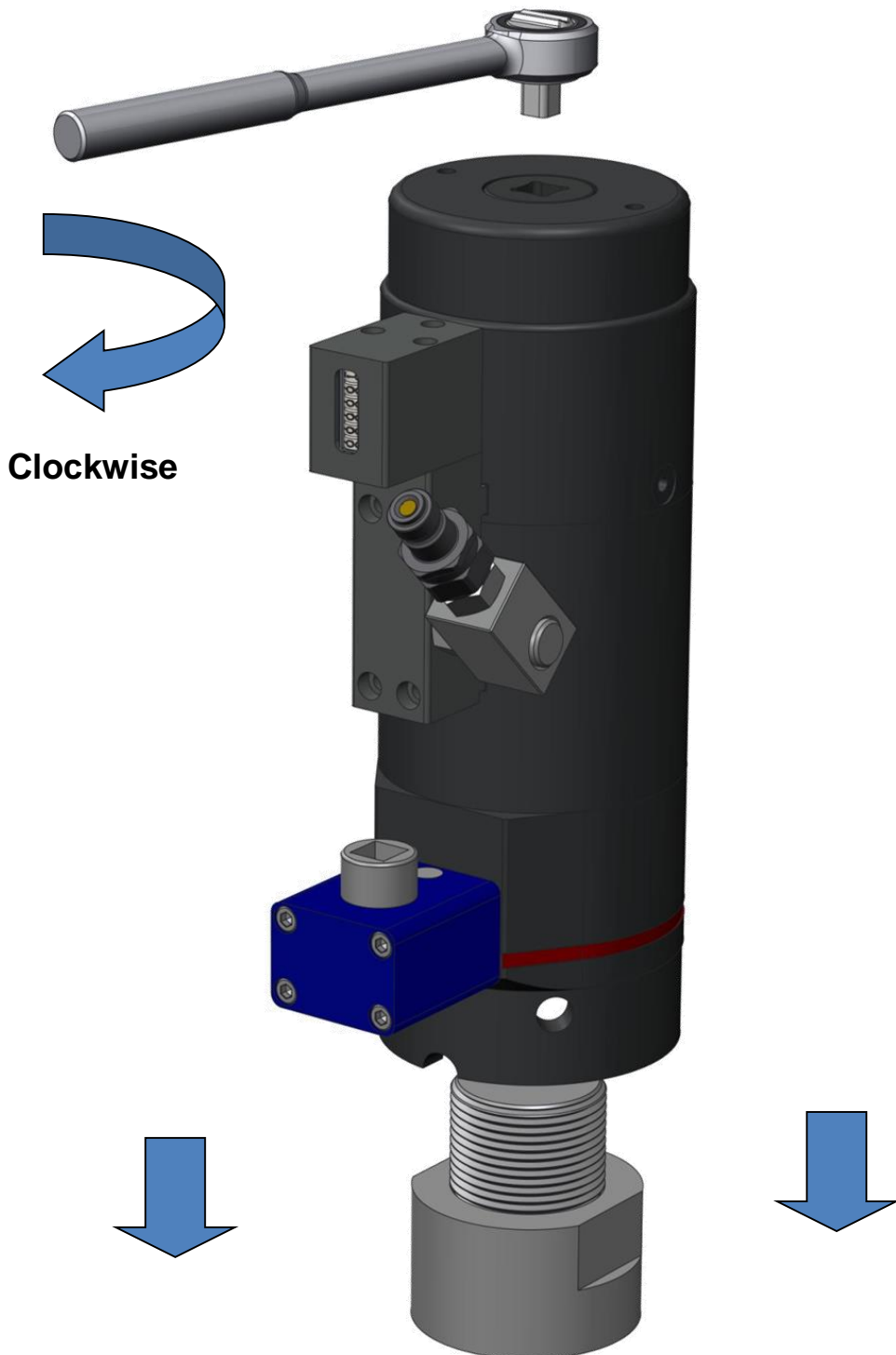

Continue rotating the Puller, increasing its engagement with the bolt until the bridge is flush with the flange. To ensure the tool is fully flush, it may be necessary to rotate the gearbox slightly whilst lowering to fully engage the gear driven socket with the nut.

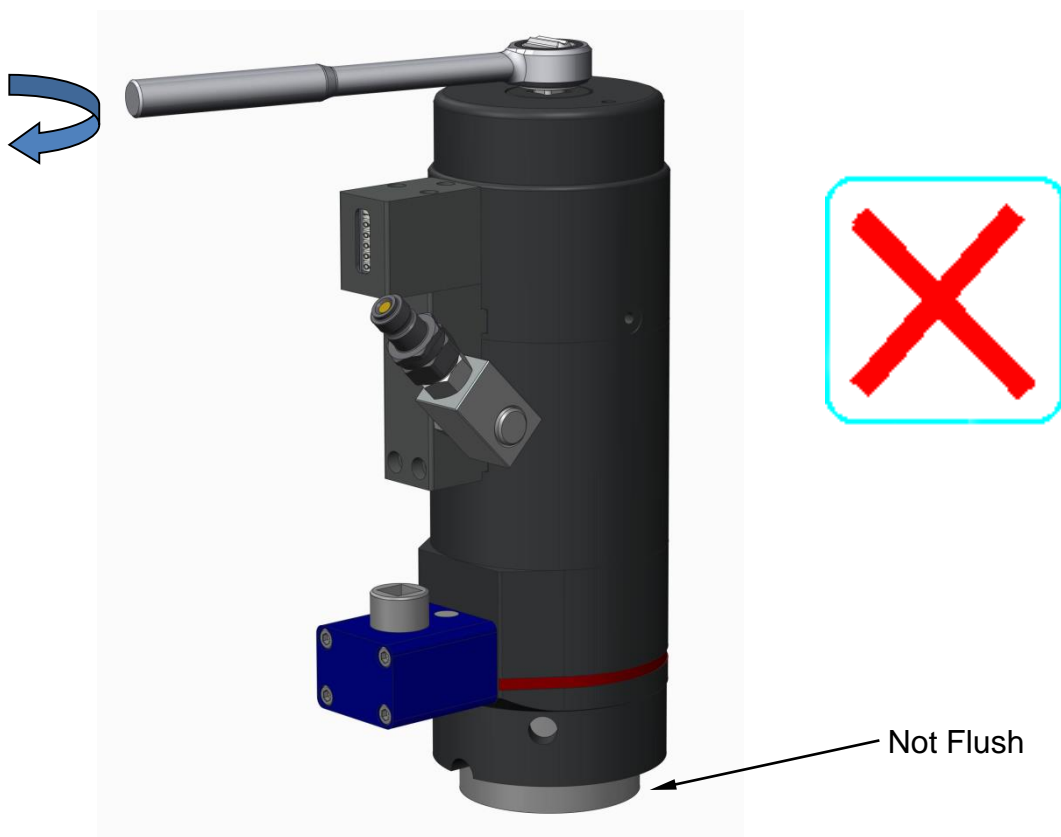
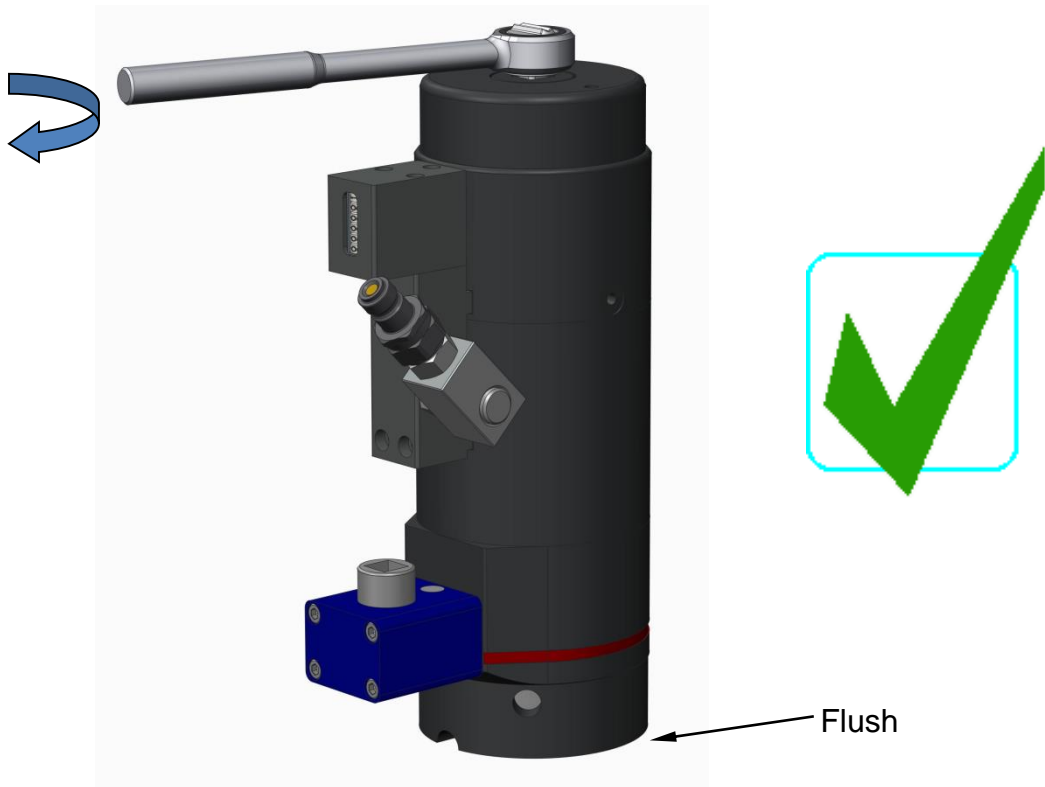

Once the Tensioner is in situ, it should still be possible to rotate the bridge to a suitable angle to access the bolt if required.

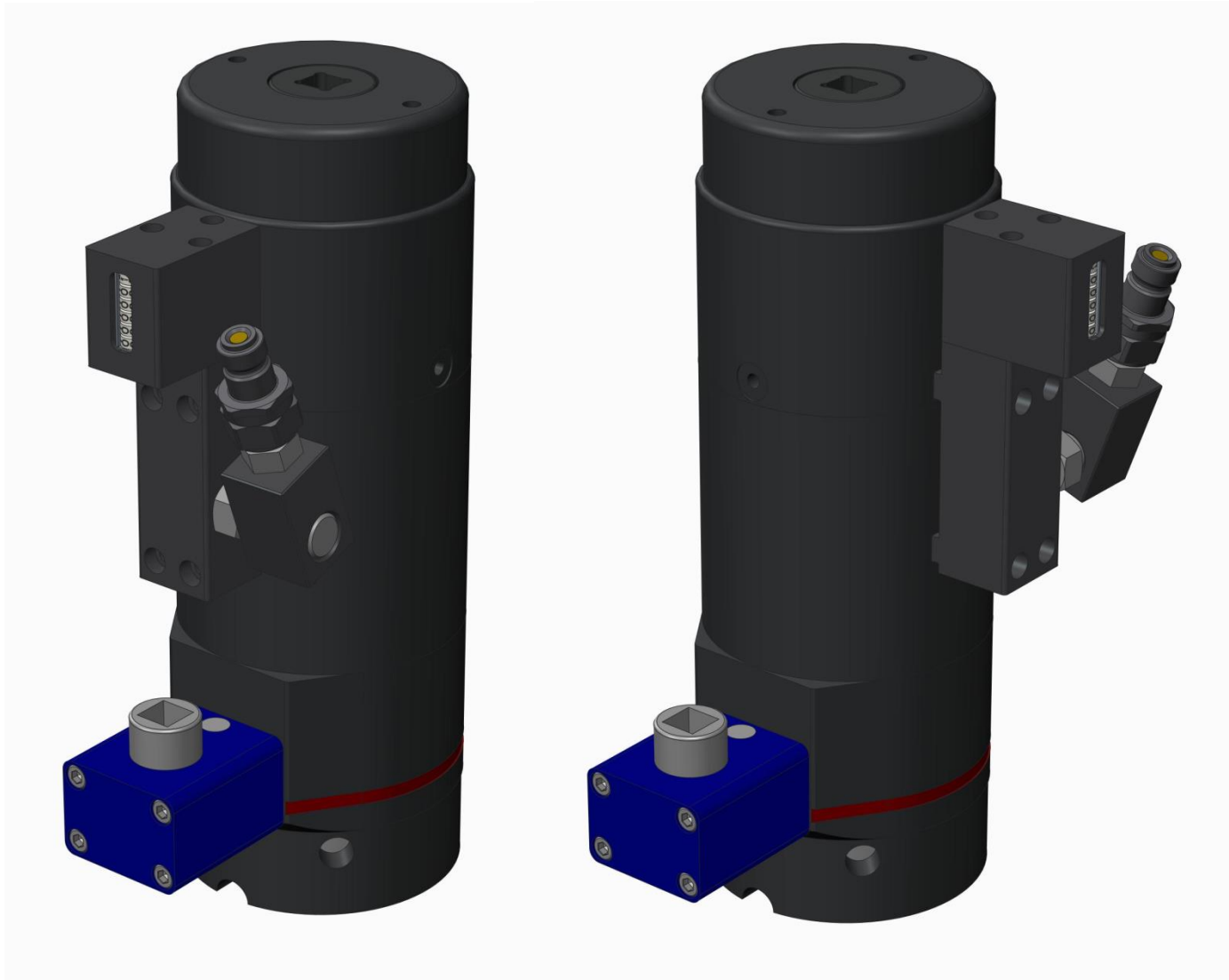

Using Quick Connectors

Before using Quick Connectors the operator should ensure that they have read and understood the Quick Connectors Health and Safety instructions in section 1. To connect the Quick Connect Coupling and Nipple, first check there is no pressure in the system. Then pull back the shroud by hand and push the coupling onto the nipple. When together, release the shroud which will spring back to lock the Coupling and Nipple together. To disconnect, first check there is no pressure in the system. Pull back the shroud, by hand, and pull the coupling and nipple apart. Release the shroud when apart.

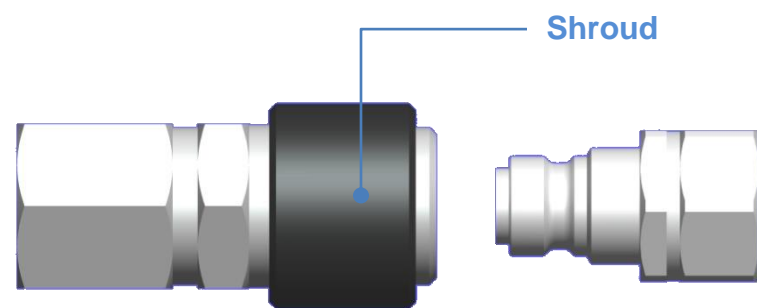

Pull the shroud back to retract.

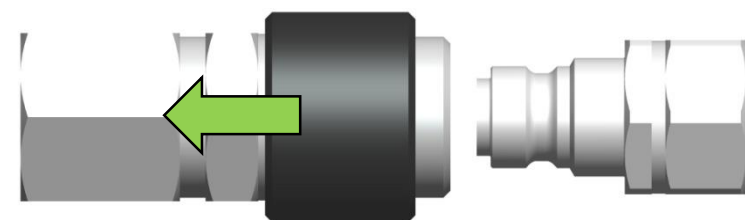

Coupling and nipple with the shroud retracted.

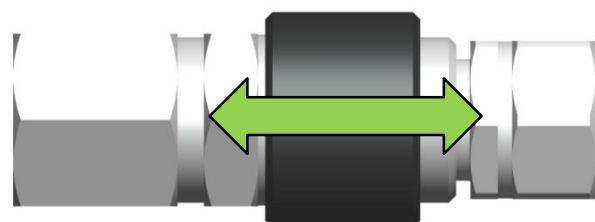

Coupling and nipple pushed together with the shroud retracted.

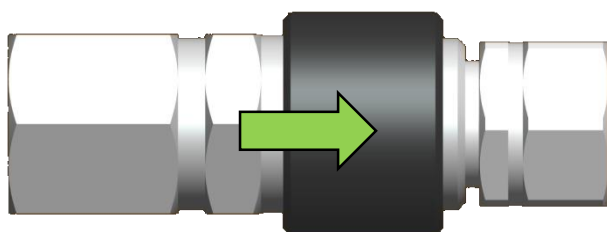

Shroud released, coupling and nipple are now locked together and safe to use.

Step 5 – Tightening a Bolt

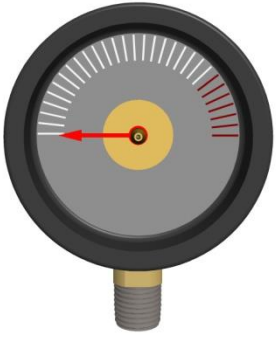

Connect a suitable high pressure hydraulic hose.

Make sure the quick connect coupling is fully engaged.

**Hydraulic
Hose**

**Quick Connect
Coupling**

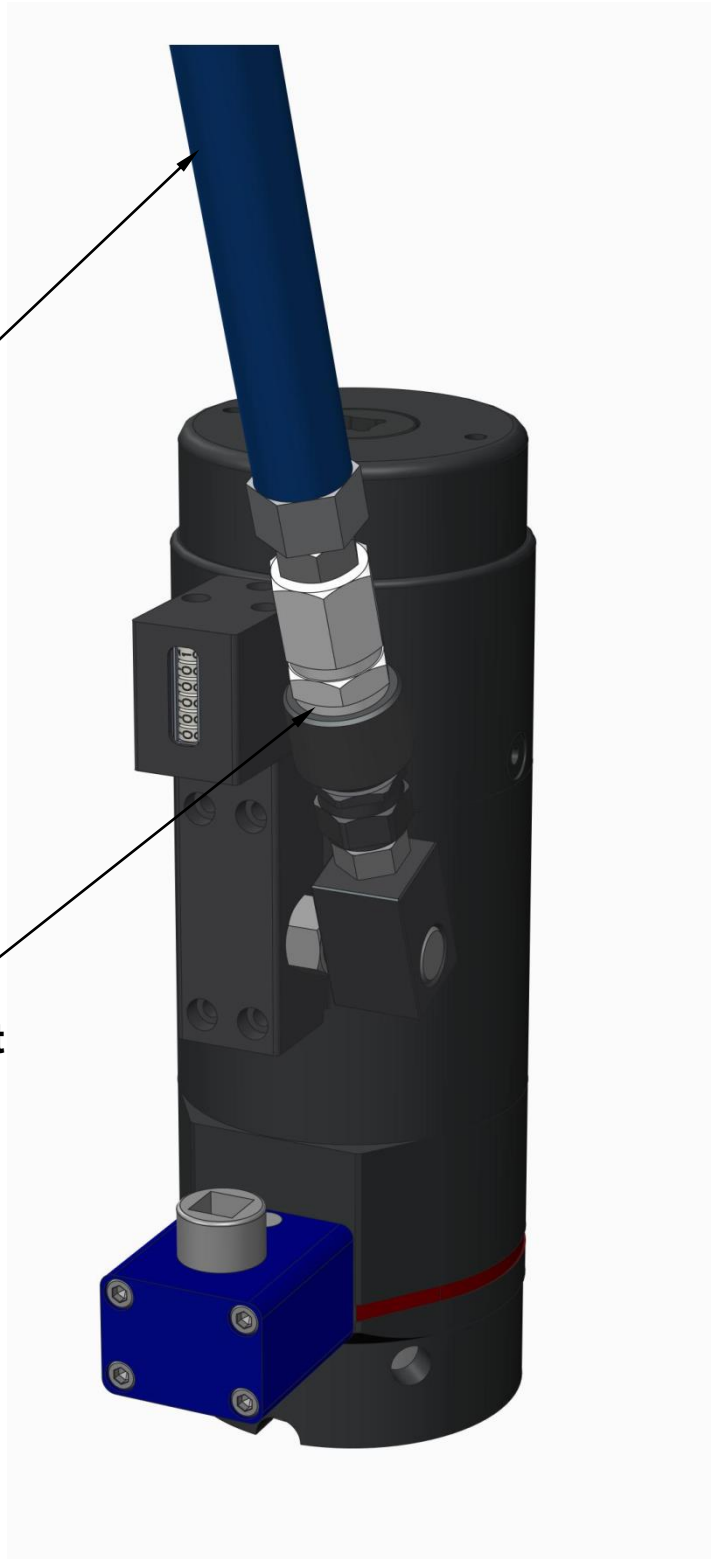

Health & Safety



THINK SAFETY

The Tensioner is now ready to be pressurised. Before proceeding, operators must familiarise themselves with the Health & Safety Instructions given in this manual, and proceed as follows:-

Clear all personnel from the area where the bolt tensioning operation is to be performed. Position the pump a safe distance away from the bolt tensioners. Set up barriers and warning signs, or make other adequate arrangements to prevent unauthorised personnel from accidentally straying into the bolt tensioning area.

Ensure that nobody is allowed to stand near to a bolt tensioning tool during pressurisation. At no time should anyone allow any part of their body to be positioned over the bolt axis of a bolt tensioner whilst the pressure is rising or when it is pressurised. Do not allow anyone to stand anywhere in or near the axis of a bolt during the tensioning operation.

Do not approach a bolt tensioning tool whilst it is being pressurised. Remember that a damaged bolt or tool is most likely to fail at this critical time. When the operating pressure has been reached, approach a pressurised bolt tensioning tool only for as long as is necessary to rotate the ring nut. Ensure that when rotating the nut you are well outside of the tensioner's vertical axis.

PPE (Personal Protective Equipment) must be worn by all personnel using bolt tensioning tools. SAFETY GLASSES and GLOVES are essential. OVERALLS and a HARD HAT are recommended.

Never leave a pressurised bolt tensioning tool unattended.

Release the oil pressure immediately if any unauthorised person moves into the bolt tensioning area and especially if anyone stands in the axis of a bolt being tensioned.

Determine the correct working pressure for the bolts to be tightened.

Proceed with the following operations keeping the bolt tensioning tools under pressure for the minimum time necessary to complete the bolt tightening operation.

Step 6 - Tightening a Bolt



Apply the correct hydraulic pressure. The tool will begin to stroke and the operator should observe the top of the Puller ascending through the top of the tool.



DO NOT exceed the maximum stroke. This is indicated by stroke indicators around the top of the Puller.



DO NOT exceed the maximum operating pressure of the tool.

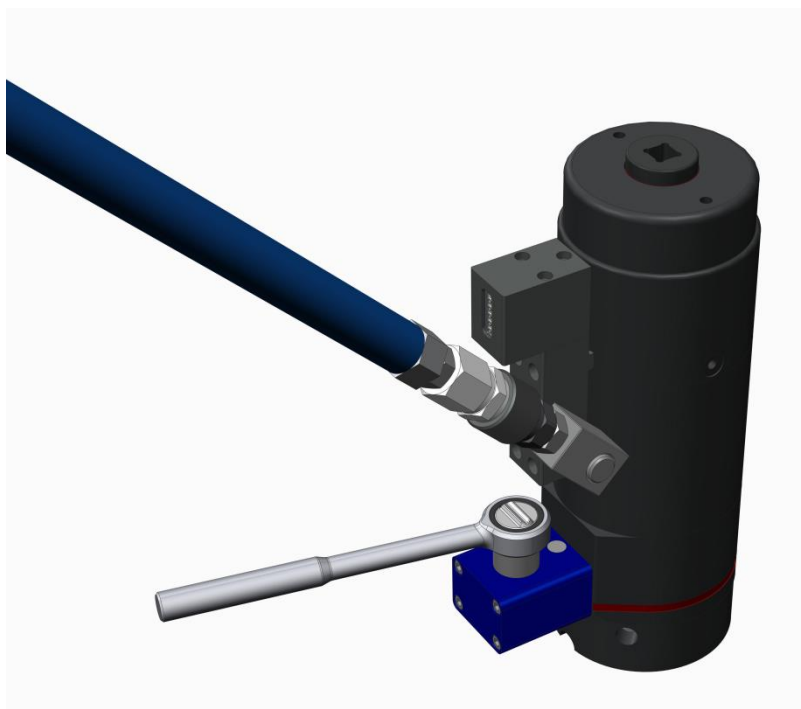

If the stroke indicators show the tensioner has reached maximum stroke before the correct hydraulic pressure has been achieved, proceed as follows :-

- Go to Step 7 - Tighten the Nut
- Go to Step 8 - Release the Pressure
- Go to Step 9 - Retracting the Tensioner
- Go to Step 10 - Reengage the tool
- Go to Step 6 - Apply the correct Pressure

If necessary repeat this sequence until the bolt tensioning tool reaches the correct oil pressure without reaching the maximum piston stroke.



Do not continue increasing the oil pressure when the bolt tensioning tool has reached maximum stroke. Increasing the pressure achieves no increase in bolt tension because no further elongation can be achieved.

Step 7 – Tightening a Bolt



Use a ½" Drive.

Insert the Drive into Drive Socket on the top of the Gearbox.

Rotate the Socket until the Nut is tight.



DO NOT exceed the maximum torque of 100 Nm (74 lb-ft).

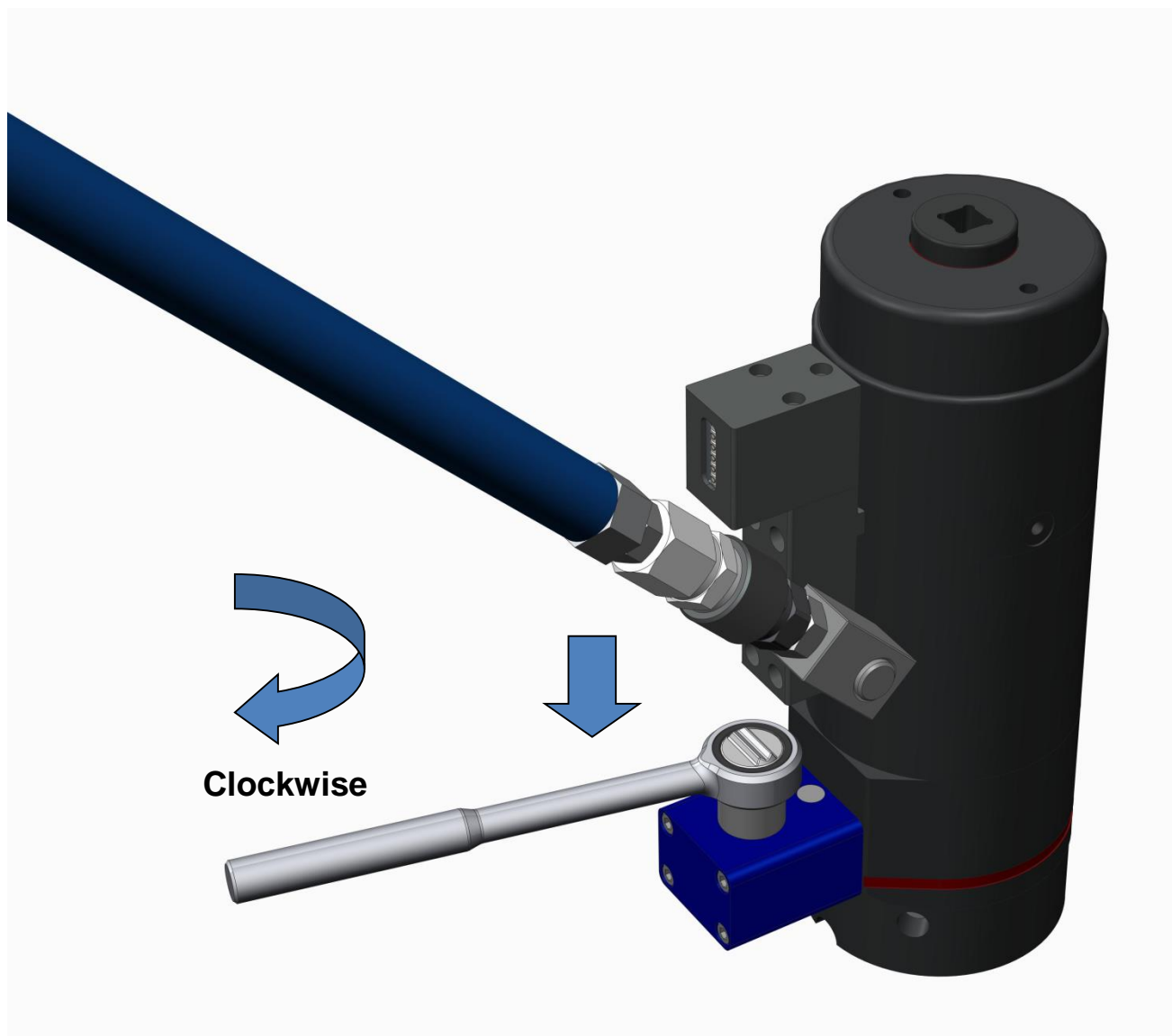

Step 8 – Tightening a Bolt



Slowly release the hydraulic pressure

Step 9 – Tightening a Bolt

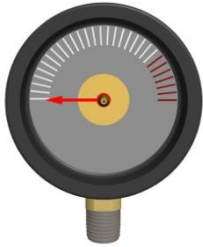

The spring retract system will now fully retract the tensioning tool.

OPTIONAL - If available, connect a Low Pressure Oil Return Hose. The hose is connected between the tool and the top of the oil reservoir on the air driven pump. This will allow the tool to retract more quickly than if the hydraulic hoses are used.

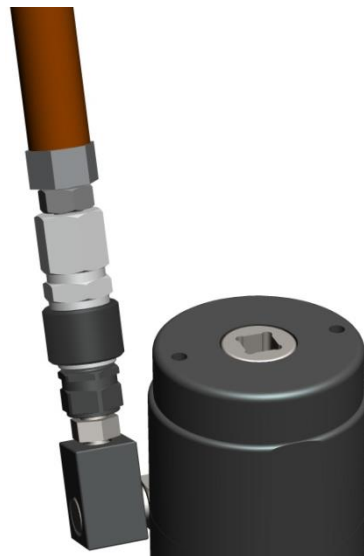
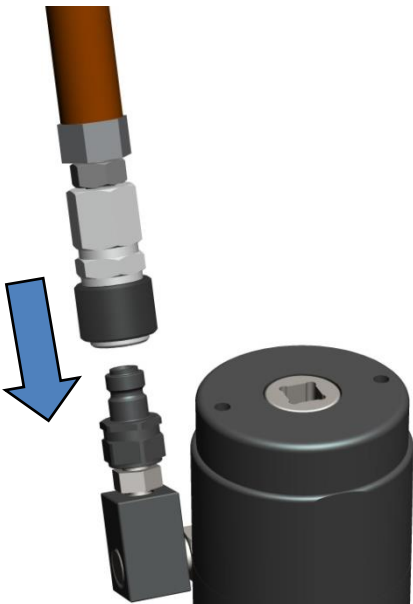
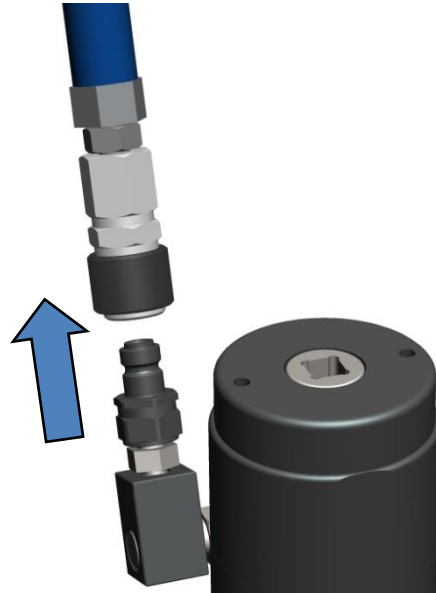

Step 10 – Tightening a Bolt

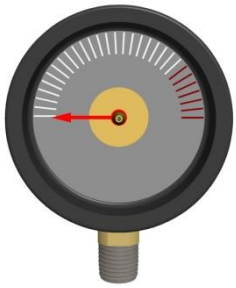

The Tensioner will have retracted upwards since the bolt will have elongated. The tool will need reengaging onto the flange.

Using the 1/2in Square Drive Socket, reengage the puller onto the stud until the tool is flush with the flange. After the tensioner is flush, continue to turn the puller ONE HALF TURN FURTHER to fully reset the tool.

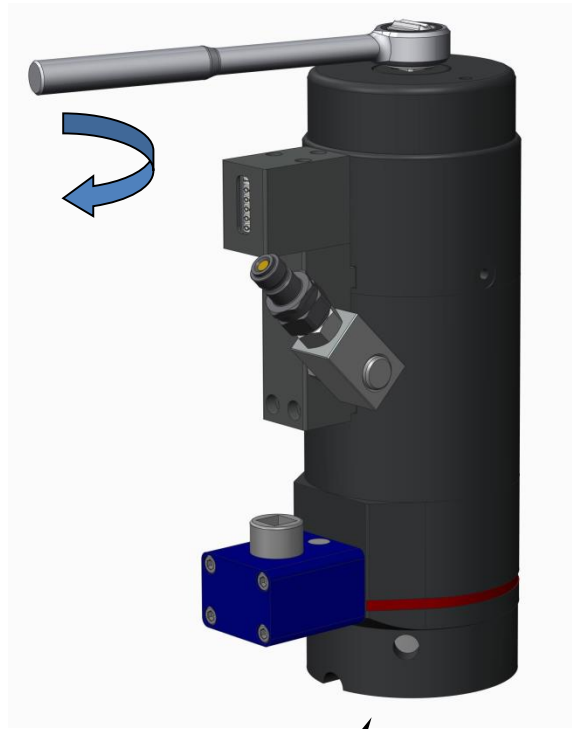
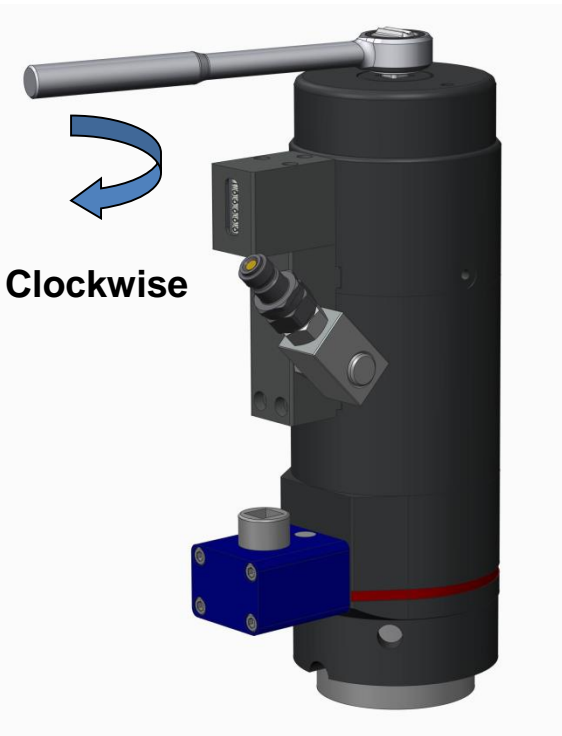

Flush
THEN ONE
ADDITIONAL
HALF TURN



Reconnect the hydraulic hose.



Step 11 – Tightening a Bolt

Apply the correct hydraulic pressure again, and wind the nut again once this is achieved.



DO NOT exceed the maximum stroke. This is indicated by stroke indicators around the top of the Puller

DO NOT exceed the Maximum Operating Pressure for the tool.

DO NOT exceed the maximum torque of 100 Nm (74 lb-ft).

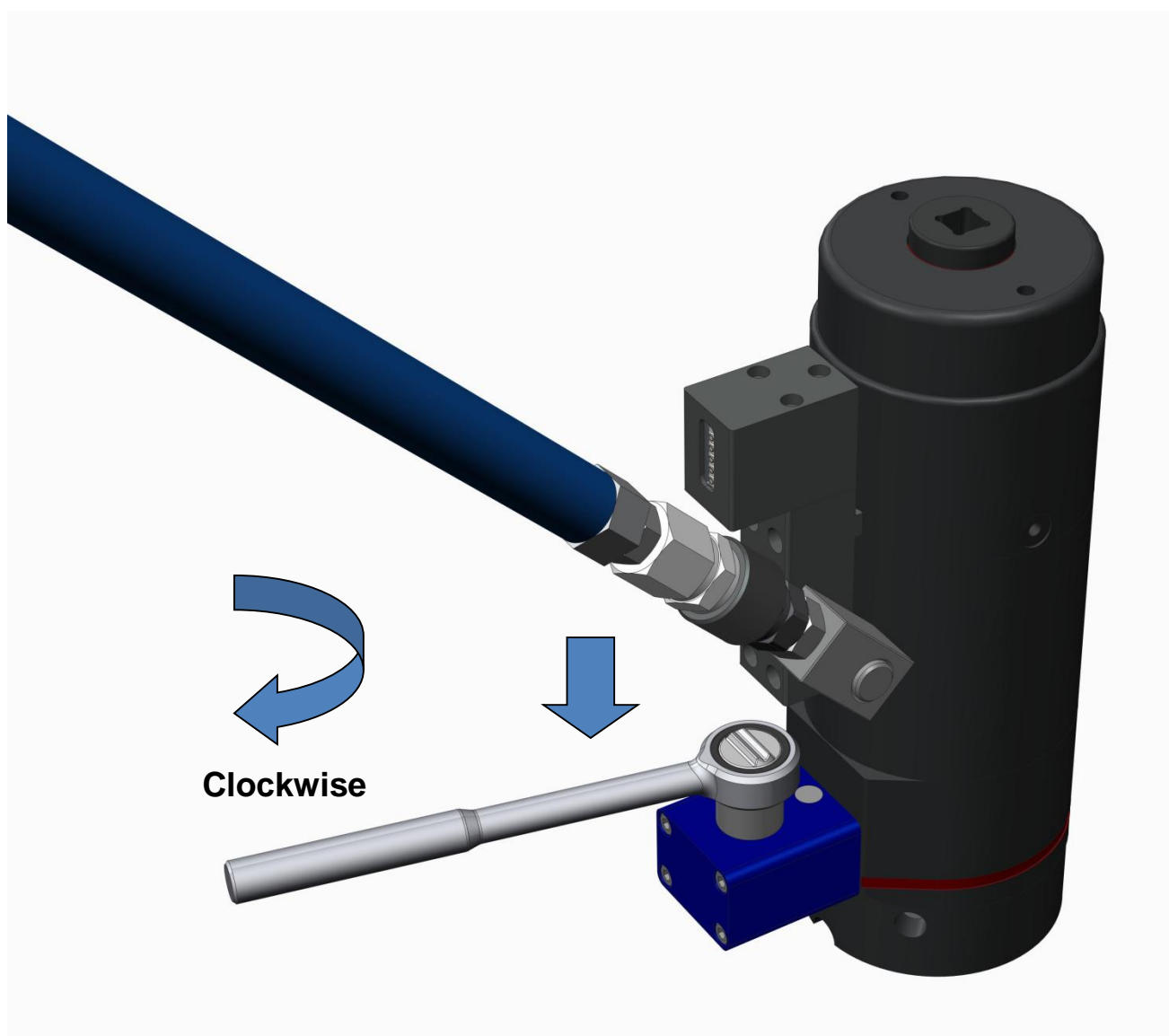

Step 12 – Tightening a Bolt

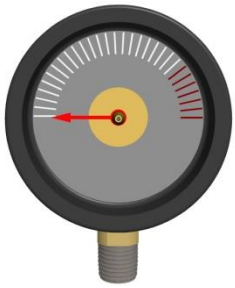

Slowly release the hydraulic pressure.

If a Low Pressure Oil Return Hose is available, attach it to accelerate retraction following the procedure outlined in Step 9. Otherwise, allow the tool to retract through the hydraulic hose and then remove once the stroke has returned to zero.

Step 13 – Tightening a Bolt

Remove the Tensioner using the 1/2in Square Drive in the top of the Puller.

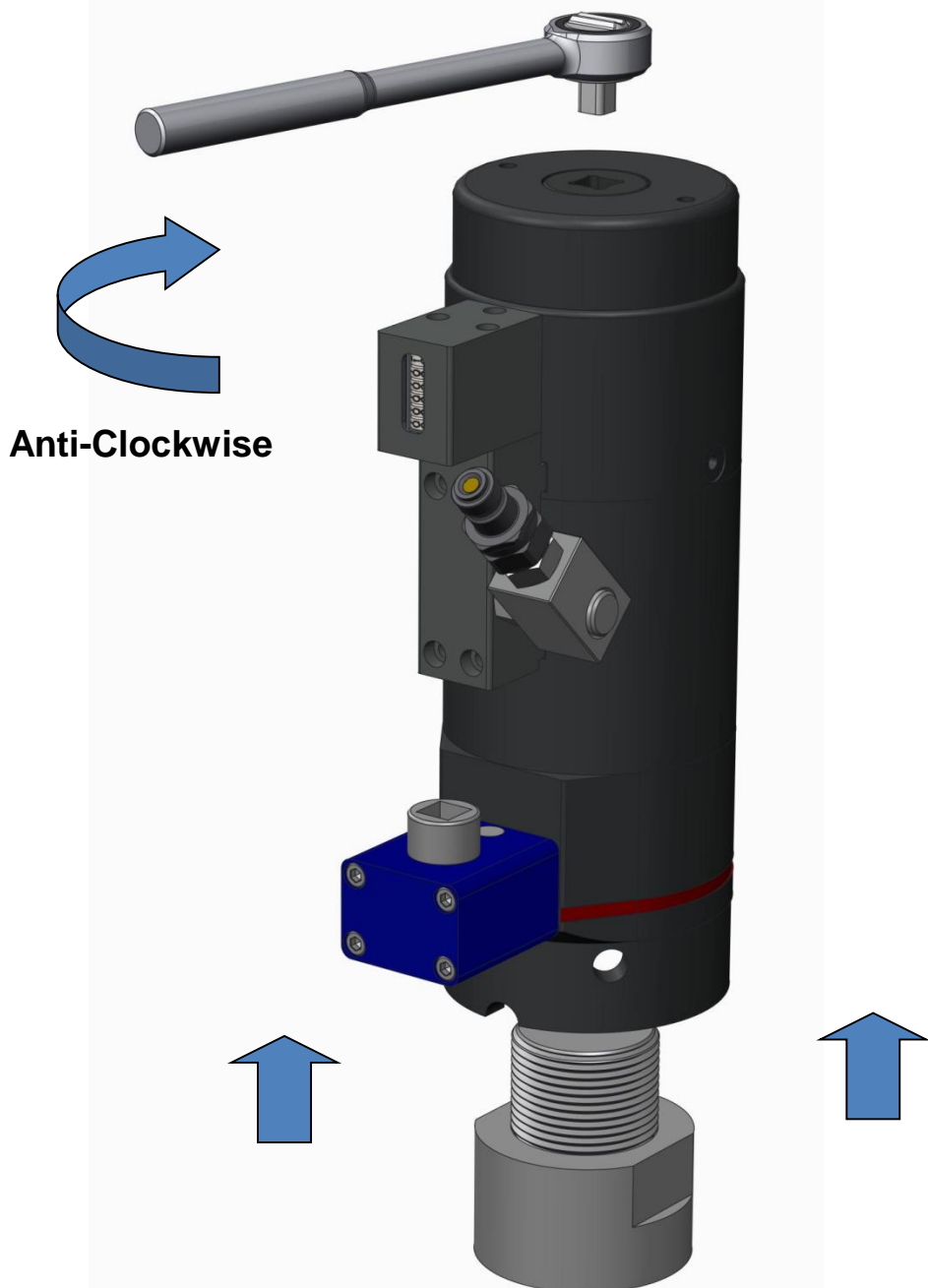

Step 1 – Loosening a Bolt

Before commencing the bolt tensioning operation read and comply with all of the Health & Safety Instructions in Section 2. Operators should also be familiar with the 'Important Information' literature in Sections 1 and 5.

Step 2 – Loosening a Bolt

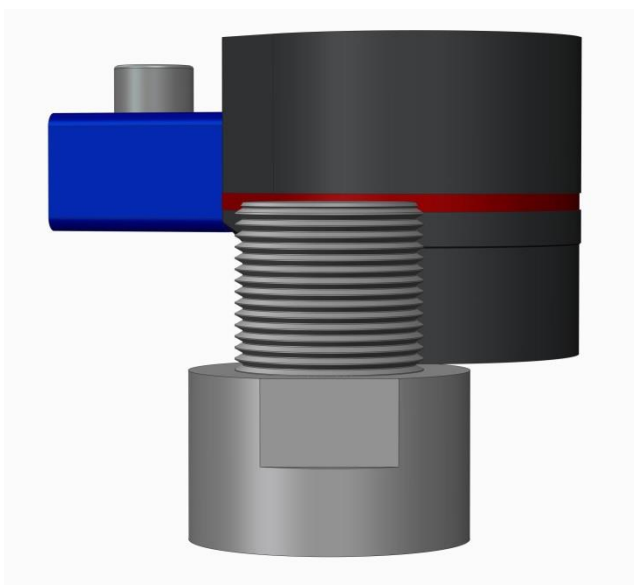

Ensure that sufficient bolt is protruding to engage the tensioner. The stud protrusion range is denoted by the red line on the outside of the Bridge Assembly, when it is positioned on top of the assembled nut. The stud protrusion must be within this band.

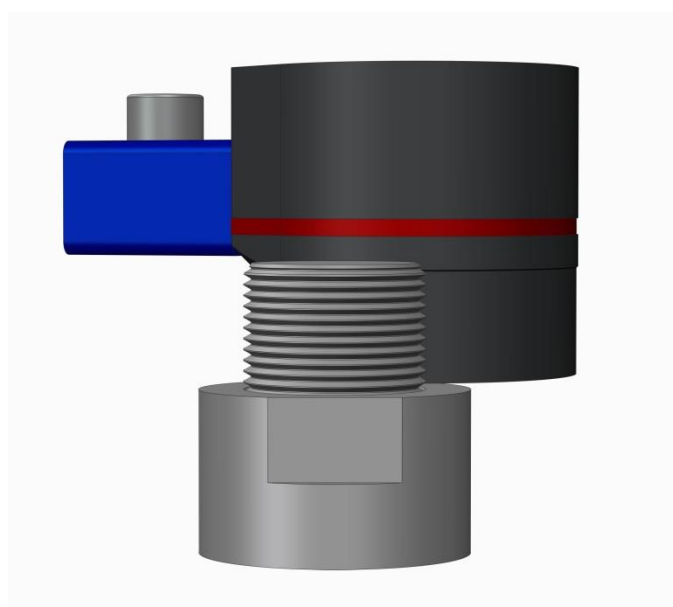

Either the stud protrusion is too short or the nut is too high up the bolt. Engagement with the Tensioner is insufficient – the bolt threads may strip and cause injury.

Step 3 – Loosening a Bolt

Position the Tensioner over the bolt to be Loosened. Orient the tensioner so that manifold is accessible, and such that the bridge allows access to the gear box.

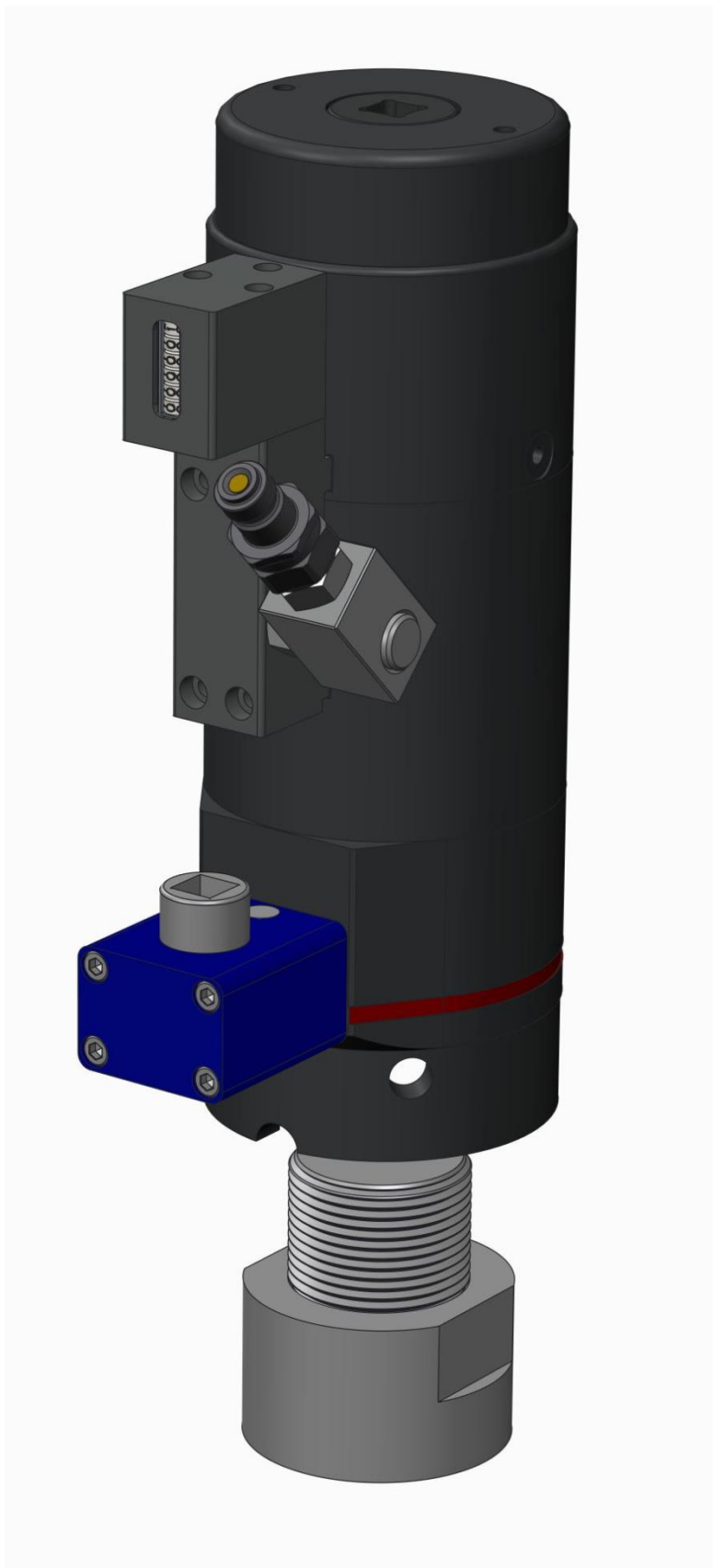

Step 4 – Loosening a Bolt

Engage the Puller with the bolt. A 1/2in Square Socket is provided in the top of the Puller Bar so that the Tensioner orientation can be maintained whilst the Puller engages the bolt.

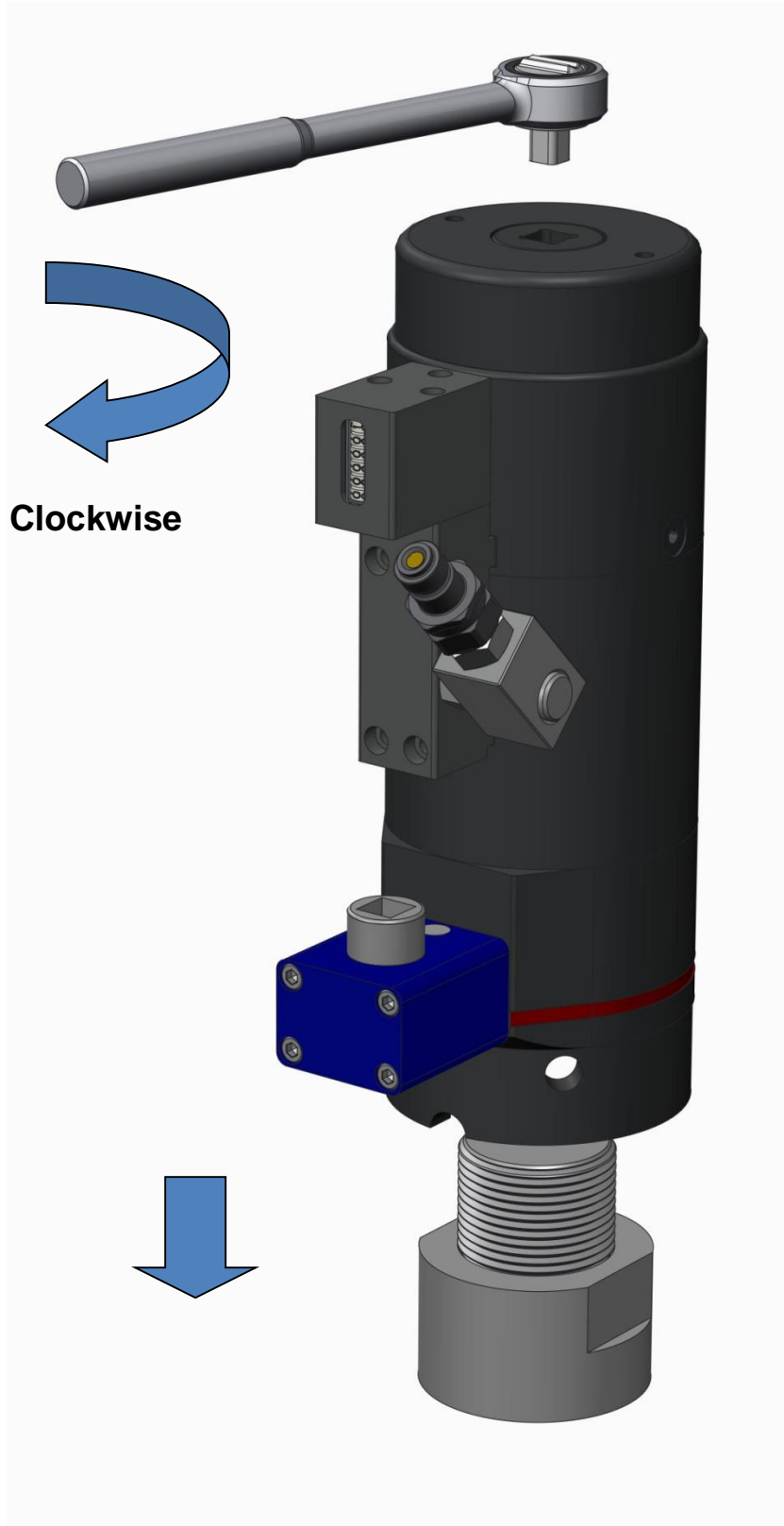

Continue rotating the Puller, increasing its engagement with the bolt until the bridge is flush with the washer. To ensure the tool is fully flush, it may be necessary to rotate the gearbox slightly whilst lowering to fully engage the gear driven socket with the nut.

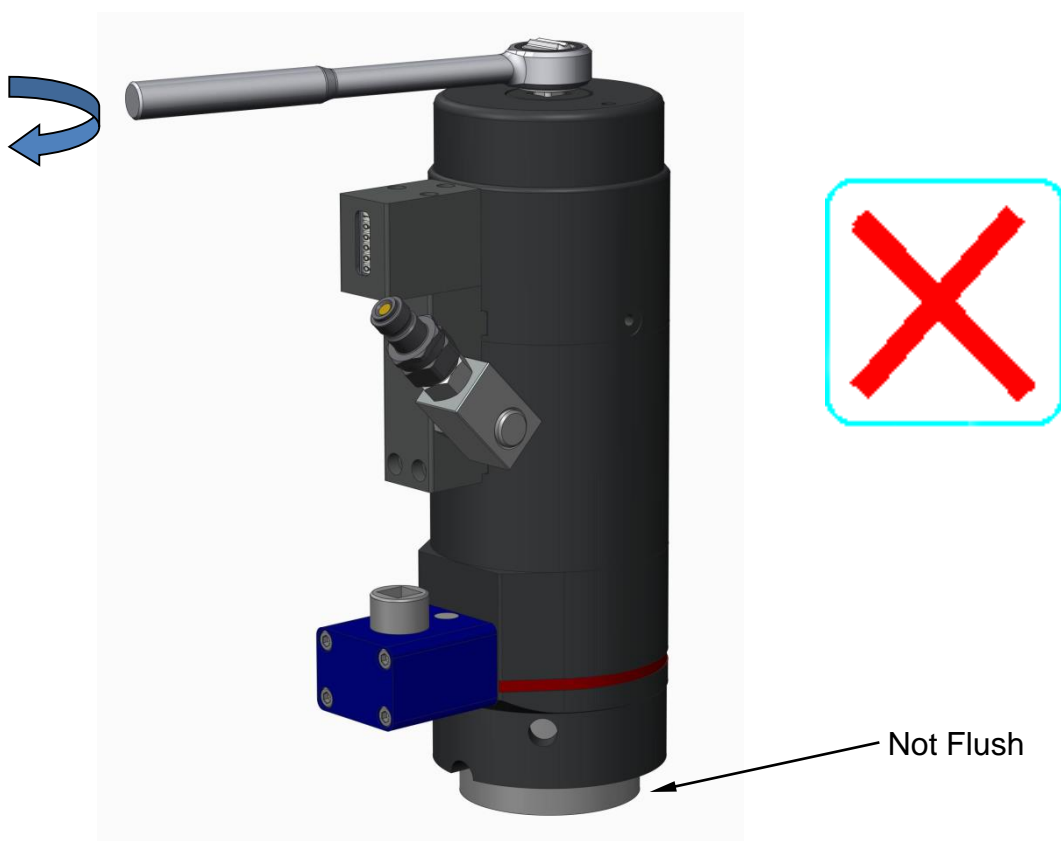
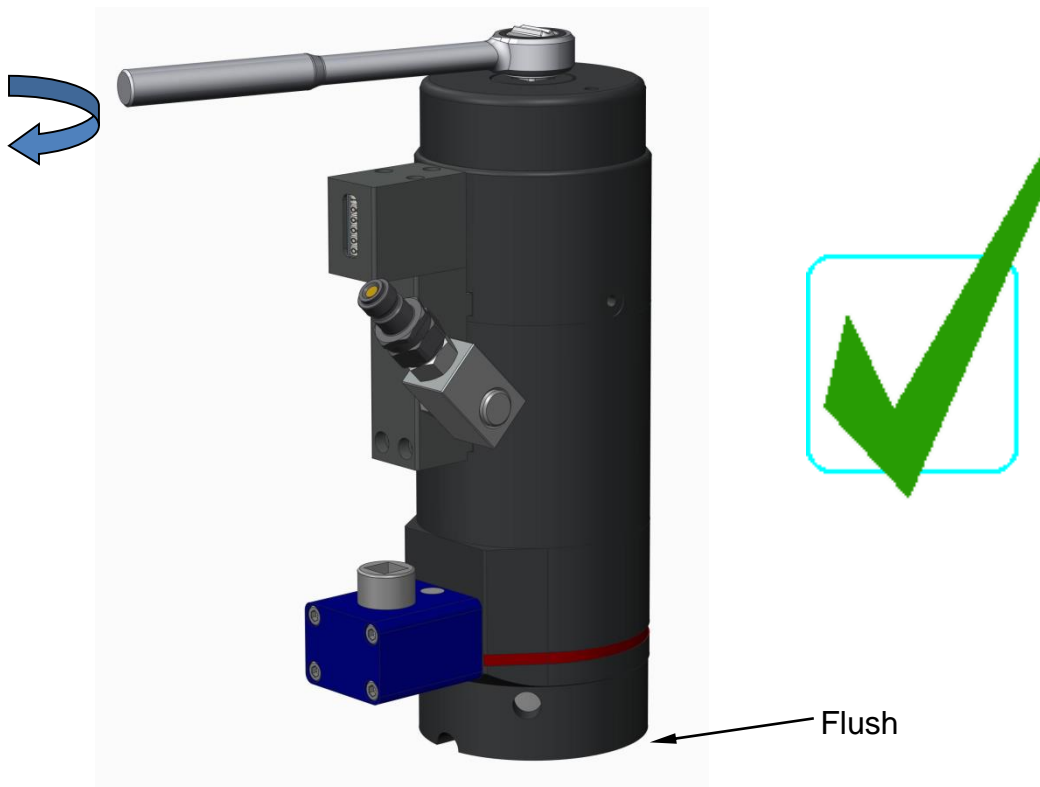

Step 5 – Loosening a Bolt

Now rotate the Puller ANTI-CLOCKWISE BY HALF A TURN. This is to prevent the Tensioner from locking onto the stud.

Anti Clockwise half a turn

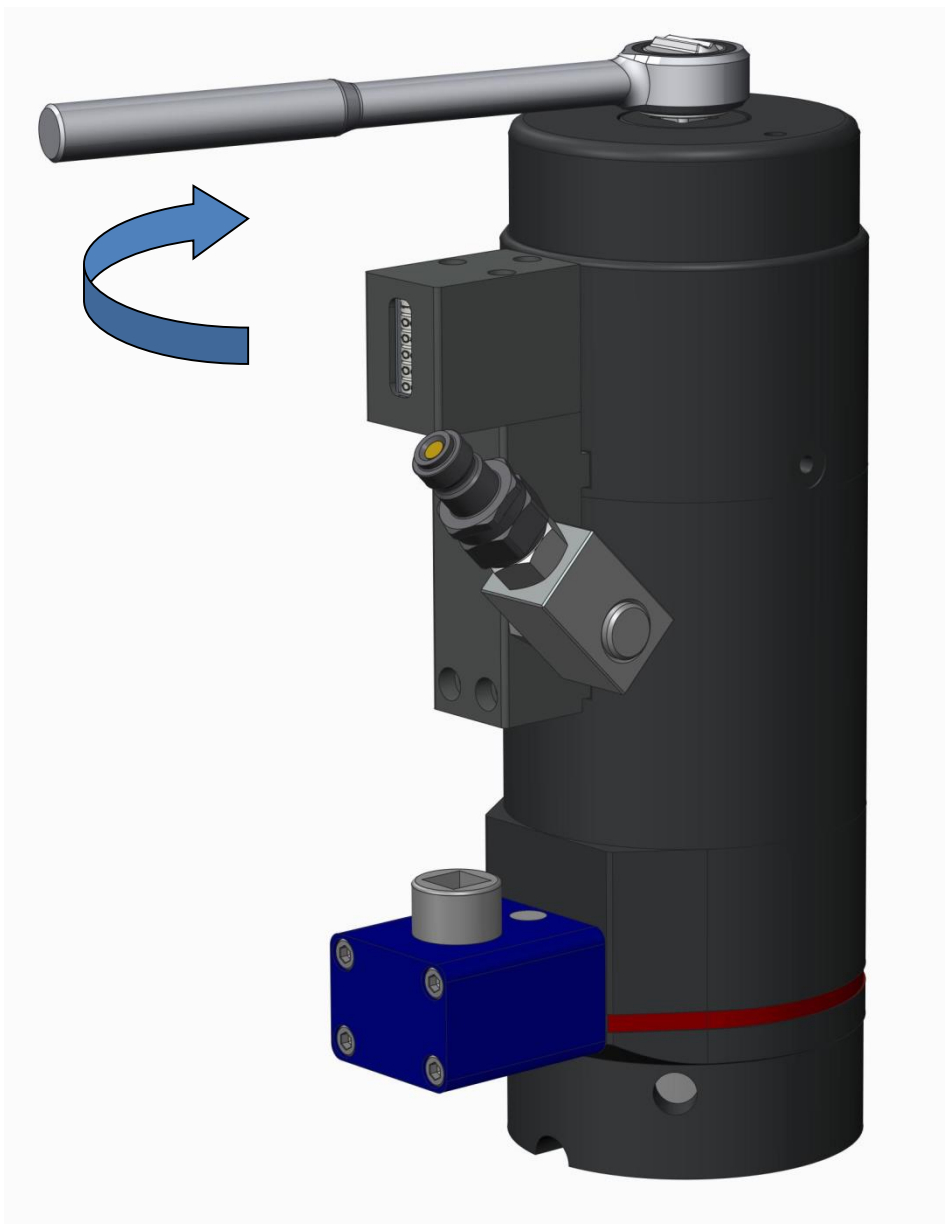

Once the Tensioner is in situ, it should still be possible to rotate the bridge to a suitable angle to access the bolt if required.

Using Quick Connectors

Before using Quick Connectors the operator should ensure that they have read and understood the Quick Connectors Health and Safety instructions in section 1. To connect the Quick Connect Coupling and Nipple, first check there is no pressure in the system. Then pull back the shroud by hand and push the coupling onto the nipple. When together, release the shroud which will spring back to lock the Coupling and Nipple together. To disconnect, first check there is no pressure in the system. Pull back the shroud, by hand, and pull the coupling and nipple apart. Release the shroud when apart.

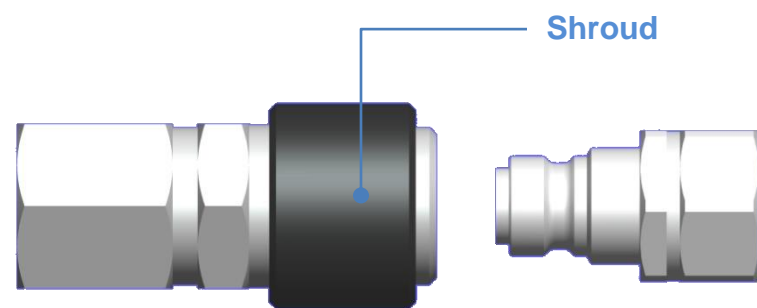

Pull the shroud back to retract.

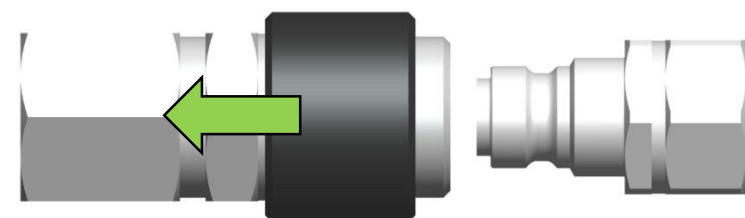

Coupling and nipple with the shroud retracted.

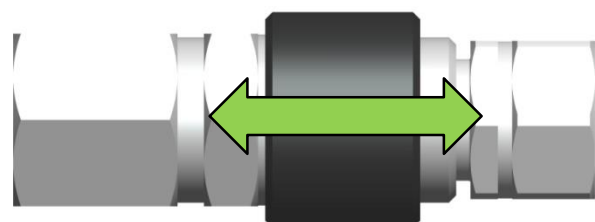

Coupling and nipple pushed together with the shroud retracted.

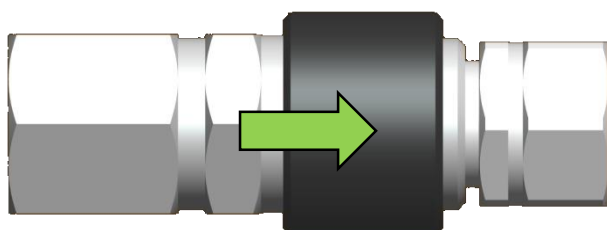

Shroud released, coupling and nipple are now locked together and safe to use.

Step 6 – Loosening a Bolt

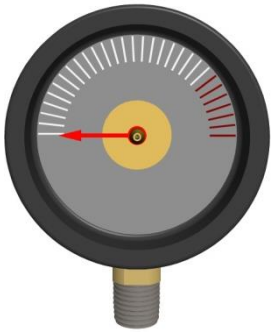

Connect a suitable high pressure hydraulic hose.

Make sure the quick connect coupling is fully engaged.

**Hydraulic
Hose**

**Quick Connect
Coupling**

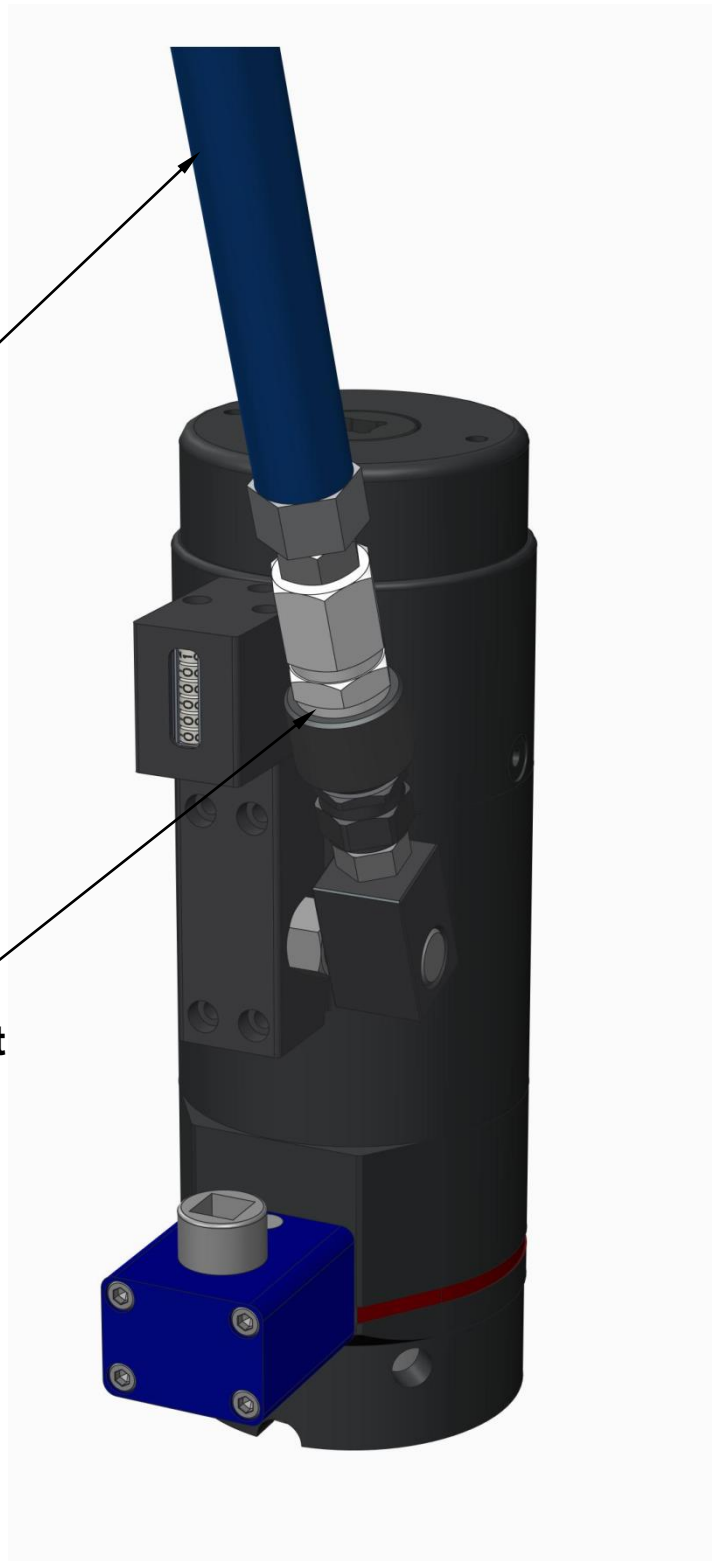

Health & Safety



THINK SAFETY

The Tensioner is now ready to be pressurised. Before proceeding, operators must familiarise themselves with the Health & Safety Instructions given in this manual, and proceed as follows:-

Clear all personnel from the area where the bolt tensioning operation is to be performed. Position the pump a safe distance away from the bolt tensioners. Set up barriers and warning signs, or make other adequate arrangements to prevent unauthorised personnel from accidentally straying into the bolt tensioning area.

Ensure that nobody is allowed to stand near to a bolt tensioning tool during pressurisation. At no time should anyone allow any part of their body to be positioned over the bolt axis of a bolt tensioner whilst the pressure is rising or when it is pressurised. Do not allow anyone to stand anywhere in or near the axis of a bolt during the tensioning operation.

Do not approach a bolt tensioning tool whilst it is being pressurised. Remember that a damaged bolt or tool is most likely to fail at this critical time. When the operating pressure has been reached, approach a pressurised bolt tensioning tool only for as long as is necessary to rotate the ring nut. Ensure that when rotating the nut you are well outside of the tensioner's vertical axis.

PPE (Personal Protective Equipment) must be worn by all personnel using bolt tensioning tools. SAFETY GLASSES and GLOVES are essential. OVERALLS and a HARD HAT are recommended.

Never leave a pressurised bolt tensioning tool unattended.

Release the oil pressure immediately if any unauthorised person moves into the bolt tensioning area and especially if anyone stands in the axis of a bolt being tensioned.

Determine the correct working pressure for the bolts to be tightened.

Proceed with the following operations keeping the bolt tensioning tools under pressure for the minimum time necessary to complete the bolt tightening operation.

Step 7 – Loosening a Bolt



Apply the correct hydraulic pressure. The tool will begin to stroke and the operator should observe the top of the Puller ascending through the top of the tool.



DO NOT exceed the maximum stroke. This is indicated by stroke indicators around the top of the Puller.



DO NOT exceed the maximum operating pressure of the tool.

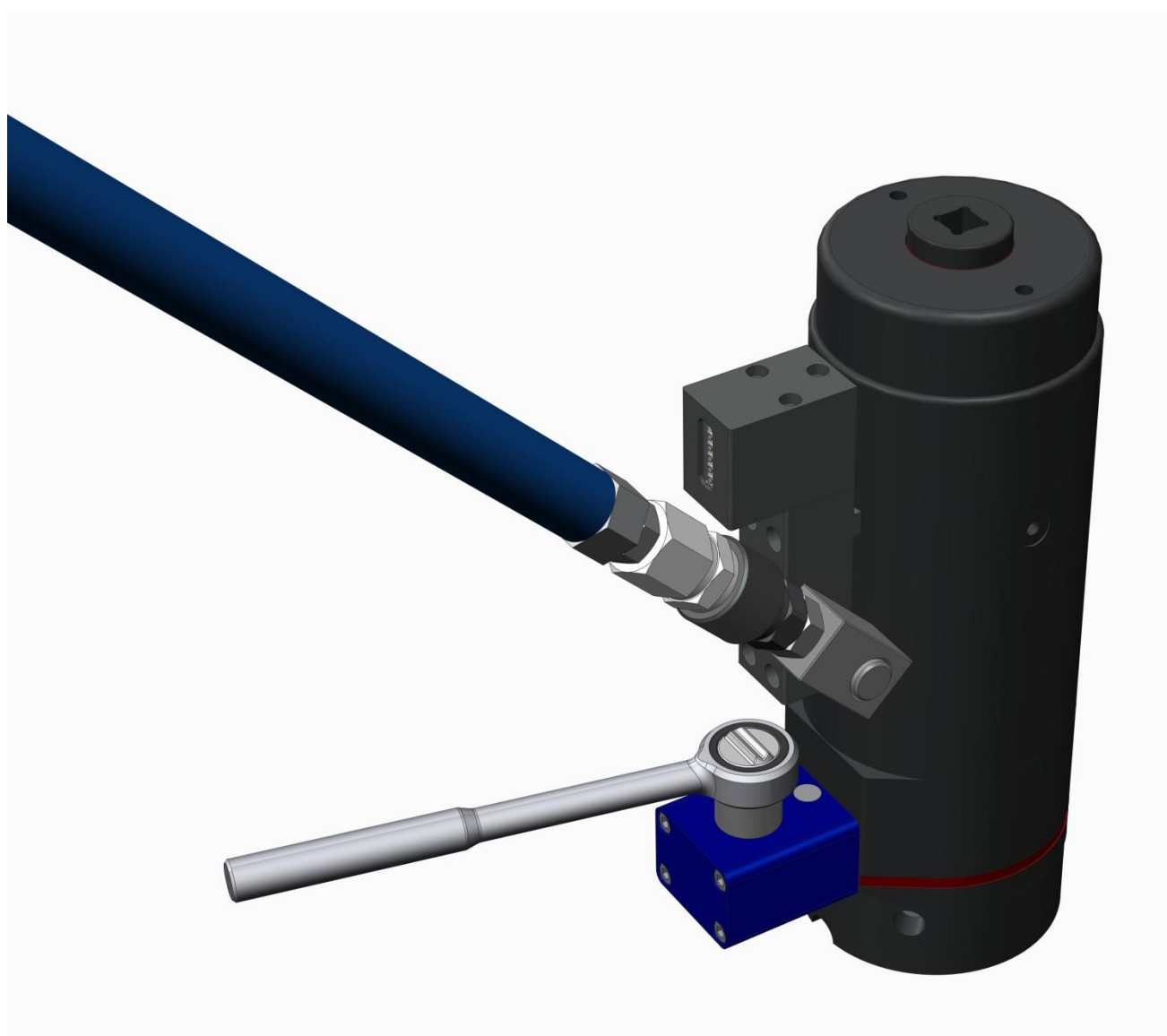

Step 8 – Loosening a Bolt



Use a ½" Drive.

Insert the Drive into Drive Socket on the top of the Gearbox.

Rotate the Socket until the Nut is loose and clear of the flange.



DO NOT exceed the maximum torque of 100 Nm (74 lb-ft).

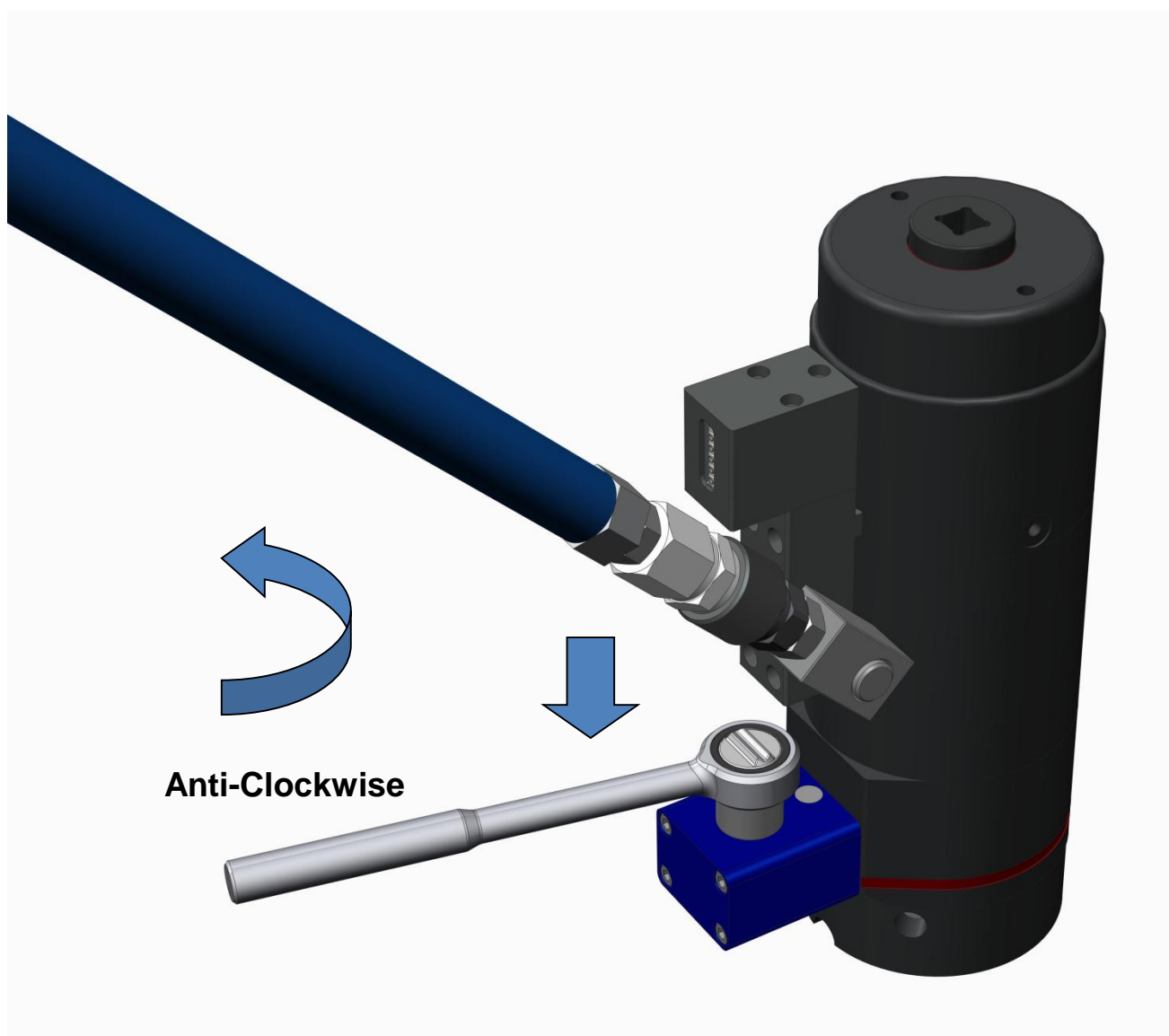

Step 9 – Loosening a Bolt

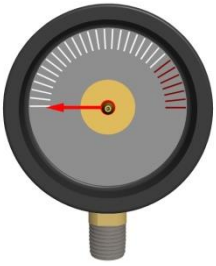

Slowly release the hydraulic pressure

Step 10 – Loosening a Bolt



The spring retract system will now fully retract the tensioning tool.

OPTIONAL - If available, connect a Low Pressure Oil Return Hose. The hose is connected between the tool and the top of the oil reservoir on the air driven pump. This will allow the tool to retract more quickly than if the hydraulic hoses are used.

The Tensioner will have retracted upwards since the bolt will have elongated. The tool will need reengaging onto the flange.

Using the 1/2in Square Drive Socket, reengage the puller onto the stud until the tool is flush with the flange. After the tensioner is flush, continue to turn the puller ONE HALF TURN FURTHER to fully reset the tool. Remove the hose once the stroke has returned to zero.

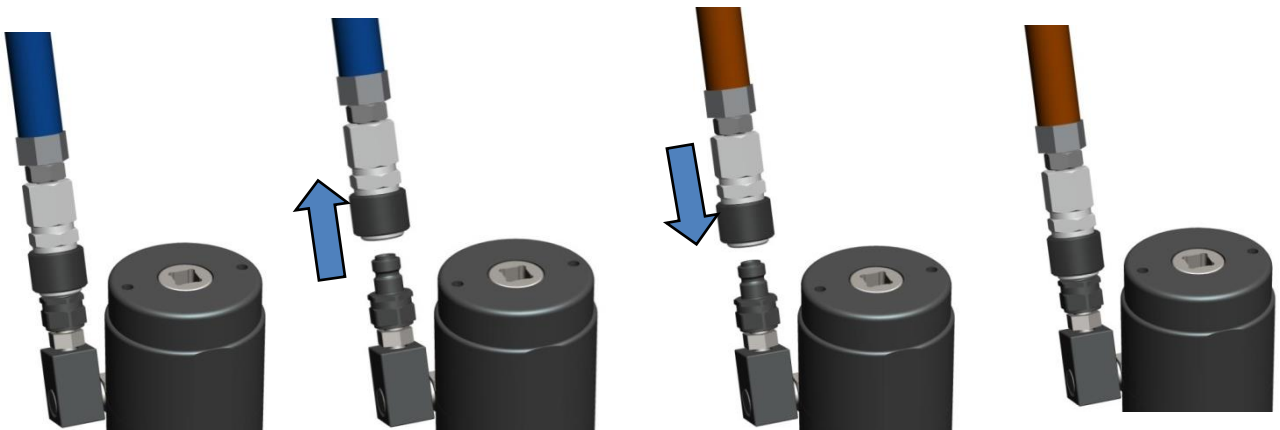

Step 11 – Loosening a Bolt

Remove the Tensioner using the 1/2in Square Drive in the top of the Puller.

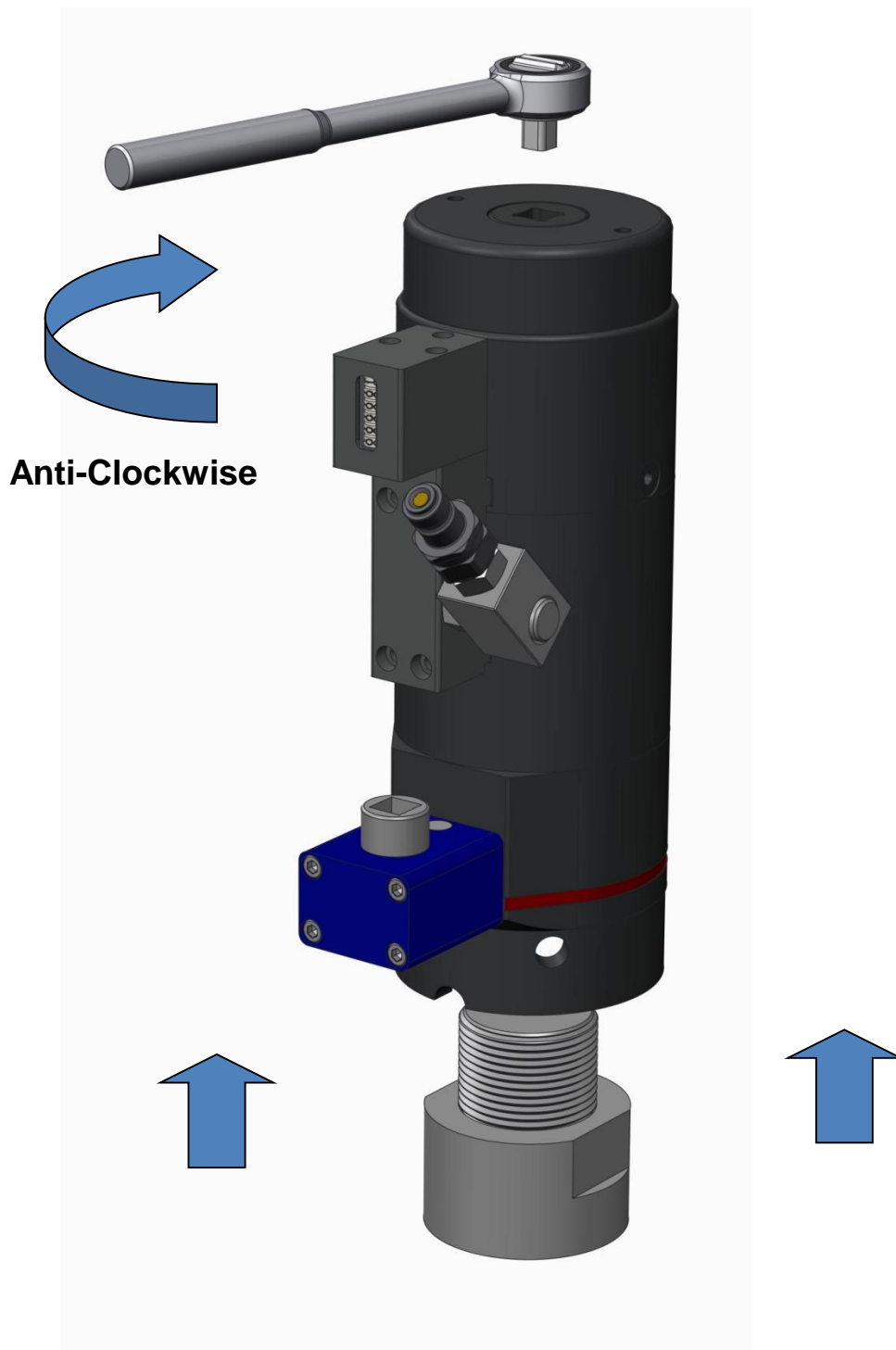

Section 4

Maintenance & Storage

General Information

A hydraulic bolt tensioning tool will provide many years of trouble free service if used, maintained and stored correctly.

Storage

Your tools were chemically blacked before leaving the factory. This provides a degree of corrosion protection but additional protection should be applied when the tools are to be stored for any period of time. It is recommended that, before storage, the tools should be checked for damage and if OK, lightly oiled.

Prior to storage, the tensioner must be retracted to zero stroke and the hydraulic connection must have its plastic protective cap fitted. The hydraulic bolt tensioner should be stored upright in a clean, dry environment. The tensioners were delivered in wooden cases and these can be used to store the tools.

Maintenance

Very little maintenance is required for a bolt tensioning tool. The only items which may require changing will be the seals and the quick connect fittings. However, the seals have a very long life and are not expected to require attention during the life of the bolt tensioning tool. If the seals fail to hold pressure it may be necessary to change them, however owing to the complexity of the tensioner it is not recommended that the tools are dismantled and any maintenance performed by the customer.

HYTORC recommend that tools are periodically returned for factory refurbishment. Please contact us for details.

Section 5

Specification

Max Cycles - 2000

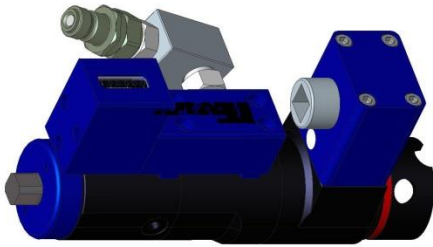

SCALE 0.500

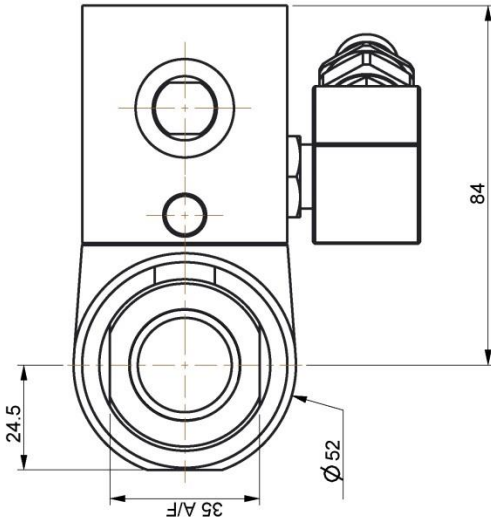

VIEW SHOWING BRIDGE PROFILE

TOOL FEATURES:

- OPTIONAL CYCLE COUNTER
- FAST SPRING RETURN
- OPTIONAL CARRYING HANDLE
- HIGH CYCLE FATIGUE LIFE
- SAFE FAILURE DESIGN
- ANTI-OVERSTROKE FACILITY
- LONG LIFE SEAL PERFORMANCE
- OPTIONAL NIPLLE/COUPLING CONFIGURATIONS
- LOW MAINTENANCE GEAR DRIVE

SPECIFICATION			
MAX WORKING PRESSURE	1500 bar	21750 psi	
MAX LOAD	240 kN	53.95 klbf	
MAX STROKE	7 mm	0.276 in	
APPROX. TOOL WEIGHT	4.1 kg	9.02 lb	

MATERIAL			
FINISH			
SURFACE FINISH		√	
LIMITS U.S.O.		±0.25 ±0.25°	
SIZE	A3	SCALE	1.000
REV	A	CNN	
		JV	
		PJ	
		07/01/15	
DRAWING NO.		HTCT-1000-21-00	
TITLE		1in 8UN MULTI STAGE CASING TENSIONER	
ISSUE		A	



THIS DRAWING AND THE DESIGN IS THE PROPERTY OF HYTORC AND IS NOT TO BE REPRODUCED OR USED IN ANY MANNER WITHOUT THE WRITTEN CONSENT OF THE COMPANY

ALL DIMS MM U.S.O.
 DO NOT SCALE

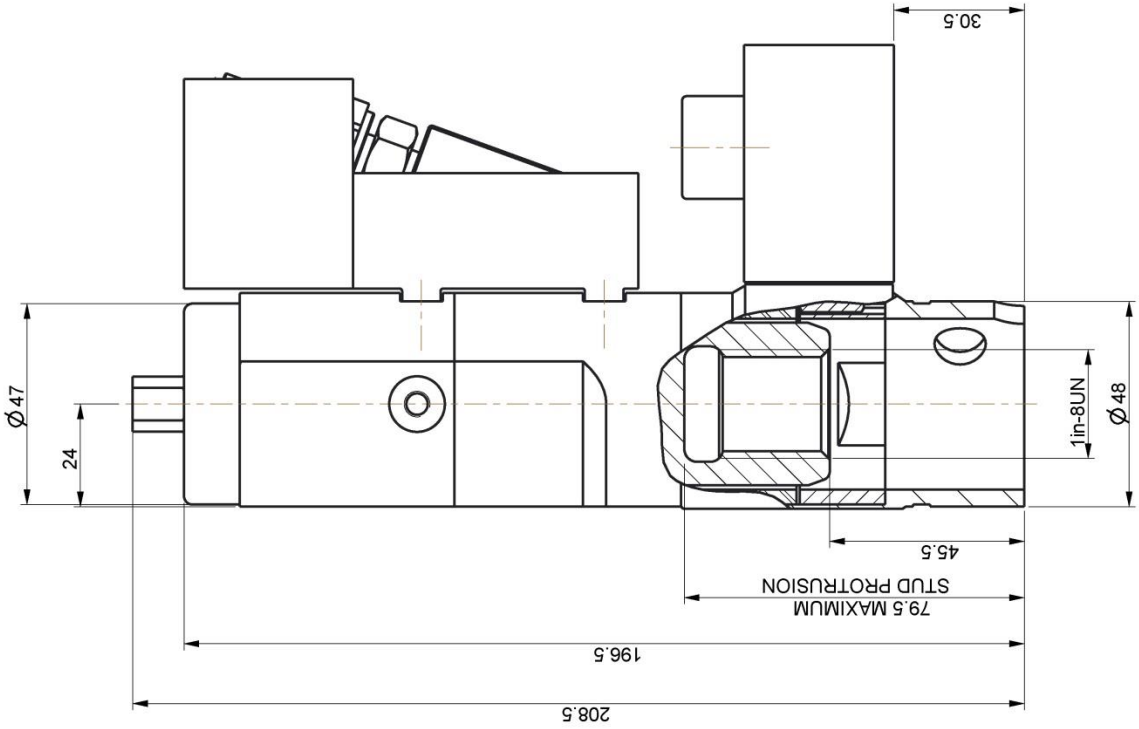

Max Cycles - 6000

THIS DRAWING AND THE DESIGN IS THE PROPERTY OF HYTORC AND IS NOT TO BE REPRODUCED OR USED IN ANY MANNER BY ANY THIRD PARTY WITHOUT THE WRITTEN CONSENT OF THE COMPANY

ALL DIMS MM U.S.O.

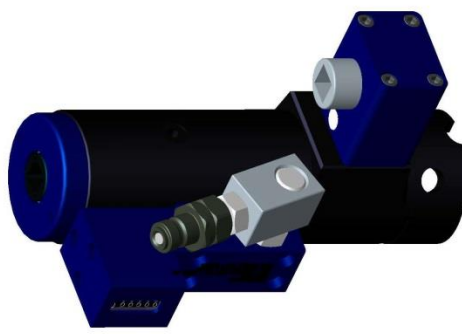
 DO NOT SCALE

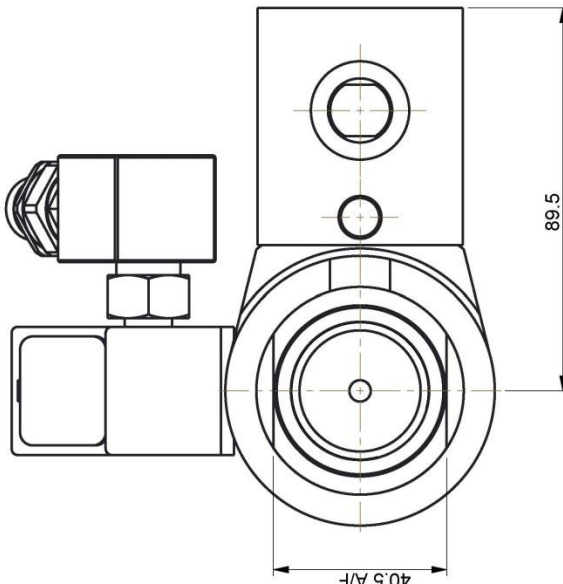

SCALE 0.500



VIEW SHOWING BRIDGE PROFILE

TOOL FEATURES:

- OPTIONAL CYCLE COUNTER
- FAST SPRING RETURN
- OPTIONAL CARRYING HANDLE
- HIGH CYCLE FATIGUE LIFE
- SAFE FAILURE DESIGN
- ANTI-OVERSTROKE FACILITY
- LONG LIFE SEAL PERFORMANCE
- OPTIONAL NIPPLE/COUPLING CONFIGURATIONS
- LOW MAINTENANCE SPRING LOADED GEAR DRIVE

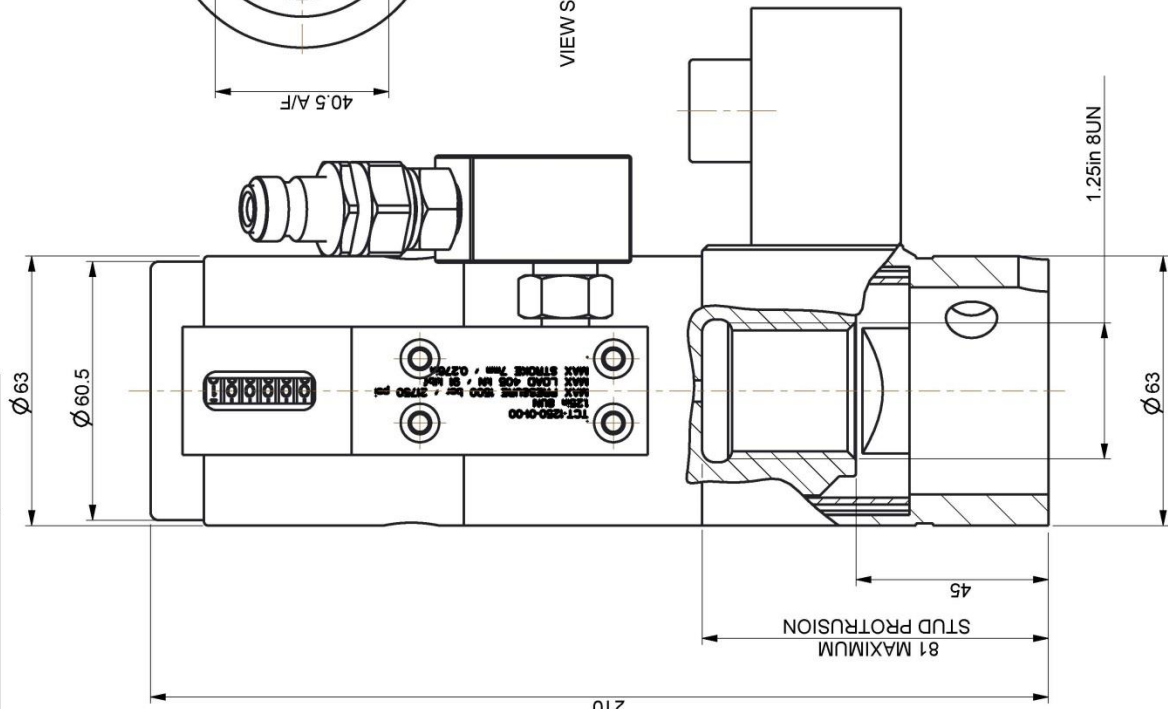

SPECIFICATION

	1500	bar	21750	psi
MAX WORKING PRESSURE	383.8	kN	86.3	kibf
MAX LOAD	7	mm	0.276	in
MAX STROKE	5.4	kg	11.9	lb
APPROX. TOOL WEIGHT				

MATERIAL			
FINISH			
SURFACE FINISH		√	
LIMITS U.S.O.		±0.25 ±0.25°	
SIZE	A3	SCALE	1.000
REV	A	CNN	
		JV	
		PJ	03/08/14
		CHECKED	DATE
TITLE		1.25in 8UN MULTI STAGE CASING TENSIONER	
DRAWING NO.		HTCT-1250-21-00	
ISSUE		A	



Max Cycles - 6000

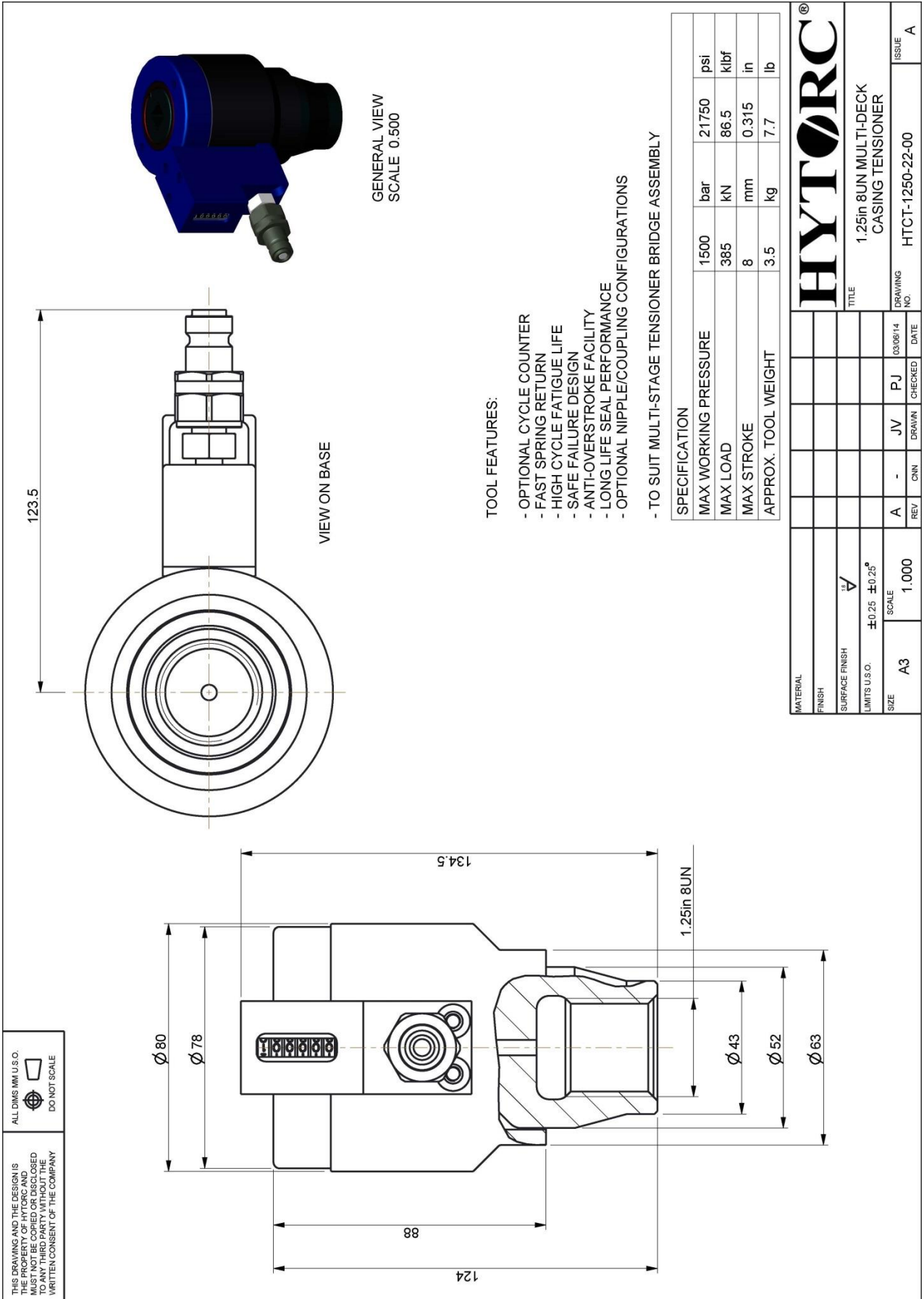

ALL DIMS MM U.S.O.
DO NOT SCALE

THIS DRAWING AND THE DESIGN IS THE PROPERTY OF HYTORC AND IS TO BE KEPT IN CONFIDENCE TO ANY THIRD PARTY WITHOUT THE WRITTEN CONSENT OF THE COMPANY

Max Cycles - 6000

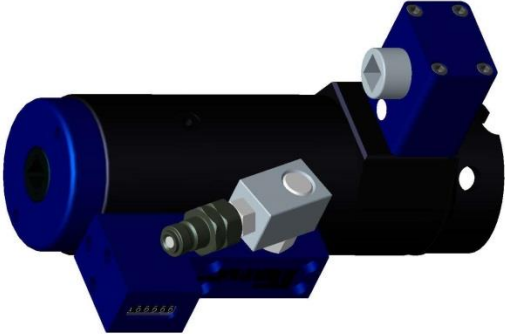

GENERAL VIEW
SCALE 0.500

TOOL FEATURES:

- OPTIONAL CYCLE COUNTER
- FAST SPRING RETURN
- OPTIONAL CARRYING HANDLE
- HIGH CYCLE FATIGUE LIFE
- SAFE FAILURE DESIGN
- ANTI-OVERSTROKE FACILITY
- LONG LIFE SEAL PERFORMANCE
- OPTIONAL NIPPLE/COUPLING CONFIGURATIONS
- LOW MAINTENANCE SPRING LOADED GEAR DRIVE

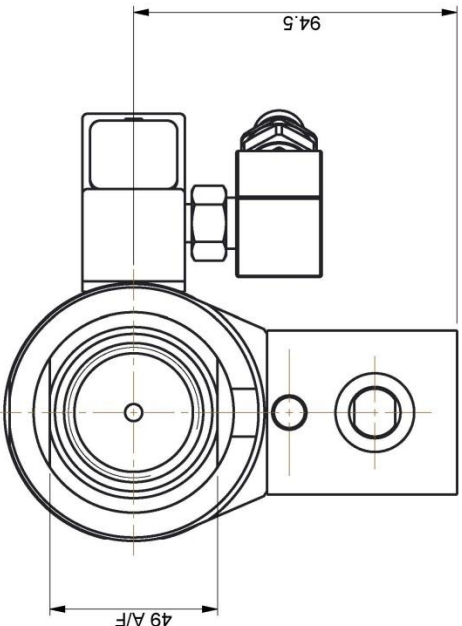

VIEW SHOWING BRIDGE PROFILE

SPECIFICATION

	1500	bar	21750	psi
MAX WORKING PRESSURE	565.4	kN	127.1	klbf
MAX LOAD	9	mm	0.354	in
MAX STROKE	8.0	kg	17.6	lb
APPROX. TOOL WEIGHT				

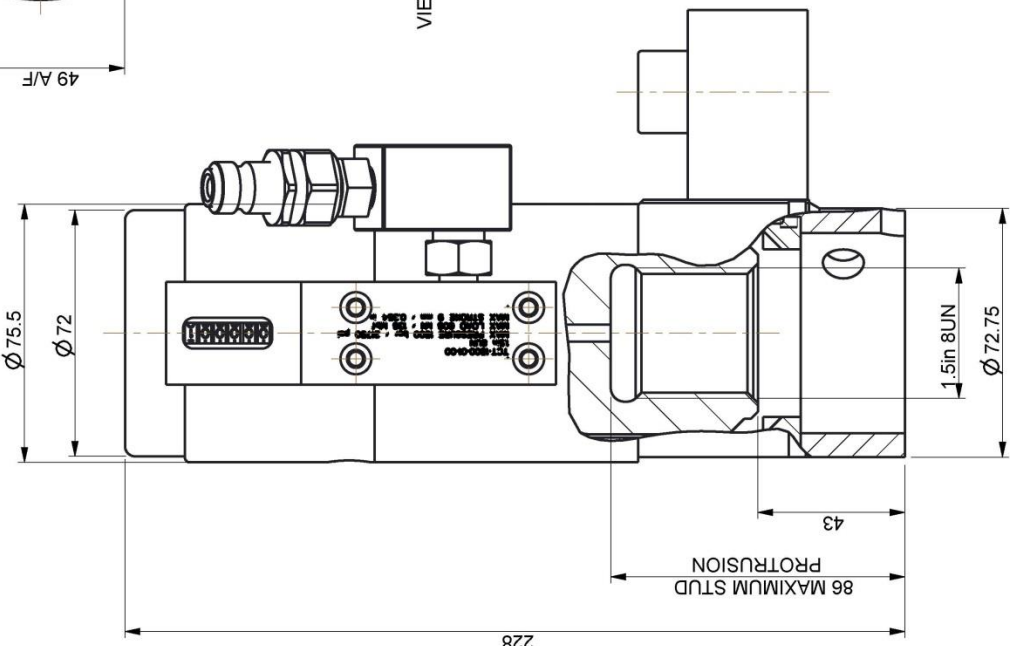

TOOL FEATURES:

- OPTIONAL CYCLE COUNTER
- FAST SPRING RETURN
- OPTIONAL CARRYING HANDLE
- HIGH CYCLE FATIGUE LIFE
- SAFE FAILURE DESIGN
- ANTI-OVERSTROKE FACILITY
- LONG LIFE SEAL PERFORMANCE
- OPTIONAL NIPPLE/COUPLING CONFIGURATIONS
- LOW MAINTENANCE SPRING LOADED GEAR DRIVE

ALL DIMS MM U.S.O.

THIS DRAWING AND THE DESIGN IS THE PROPERTY OF HYTORC AND IS TO BE USED ONLY BY THE USER TO ANY THIRD PARTY WITHOUT THE WRITTEN CONSENT OF THE COMPANY.

MATERIAL	FINISH	SURFACE FINISH	LIMITS U.S.O.	SCALE	SIZE	REV	CNN	DRAWN	CHECKED	DATE	TITLE	DRAWING NO.	ISSUE
		AV	±0.25 ±0.25°	0.800	A3	A	-	JV	PJ	03/08/14	1.5in 8UN MULTI-DECK CASING TENSIONER	HTCT-1500-21-00	A

Max Cycles - 6000

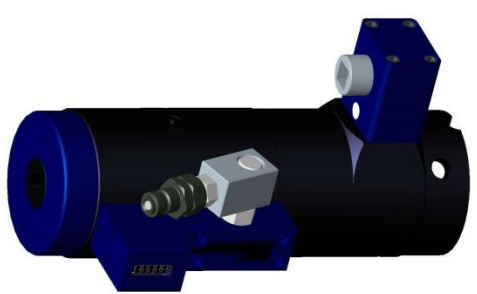

GENERAL VIEW
SCALE 0.400

TOOL FEATURES:

- FAST SPRING RETURN
- HIGH CYCLE FATIGUE LIFE
- OPTIONAL CARRYING HANDLE
- OPTIONAL SPACER (SHOWN)
- SAFE FAILURE DESIGN
- ANTI-OVERSTROKE FACILITY
- LONG LIFE SEAL PERFORMANCE
- OPTIONAL NIPPLE/COUPLING CONFIGURATIONS
- LOW MAINTENANCE SPRING LOADED GEAR DRIVE

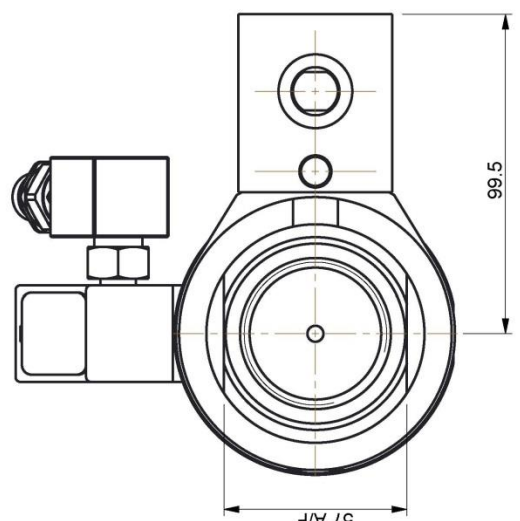

VIEW SHOWING BRIDGE PROFILE

SPECIFICATION

	1500	bar	21750	psi
MAX WORKING PRESSURE	783	kN	176	klbf
MAX LOAD	10	mm	0.394	in
MAX STROKE	12	kg	26.5	lb
APPROX. TOOL WEIGHT				

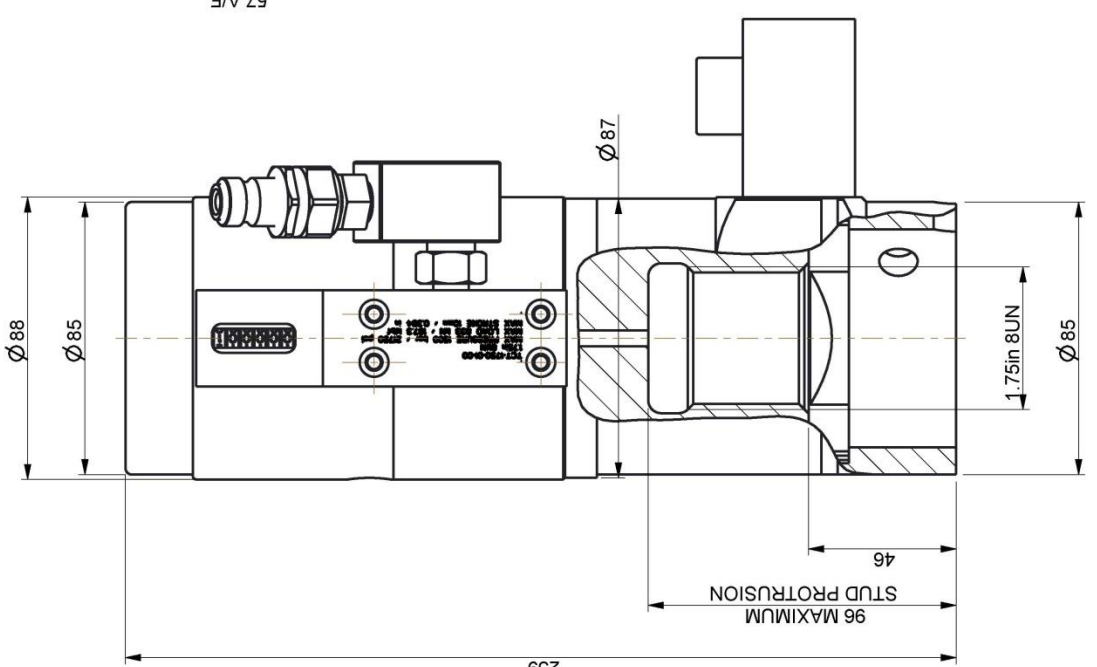

96 MAXIMUM
STUD PROTRUSION

46

1.75in 8UN

Ø 85

Ø 87

Ø 88

Ø 85

259

MATERIAL	
FINISH	
SURFACE FINISH	1.6
LIMITS U.S.O.	±0.25 ±0.25°
SIZE	A3
SCALE	0.750
REV	A
CNN	-
DRAWN	JV
CHECKED	PJ
DATE	04/08/14
DRAWING NO.	HTCT-1750-21-00
ISSUE	A

THIS DRAWING AND THE DESIGN IS THE PROPERTY OF HYTORC AND IS NOT TO BE REPRODUCED OR USED IN ANY MANNER WITHOUT THE WRITTEN CONSENT OF THE COMPANY.

ALL DIMS MM U.S.O.

DO NOT SCALE

HYTORC®

1.75in 8UN MULTI-DECK CASING TENSIONER

Max Cycles - 6000

THIS DRAWING AND THE DESIGN IS THE PROPERTY OF HYTORC AND IS NOT TO BE REPRODUCED OR USED IN ANY MANNER WITHOUT THE WRITTEN CONSENT OF THE COMPANY

ALL DIMS MM U.S.O.
 DO NOT SCALE

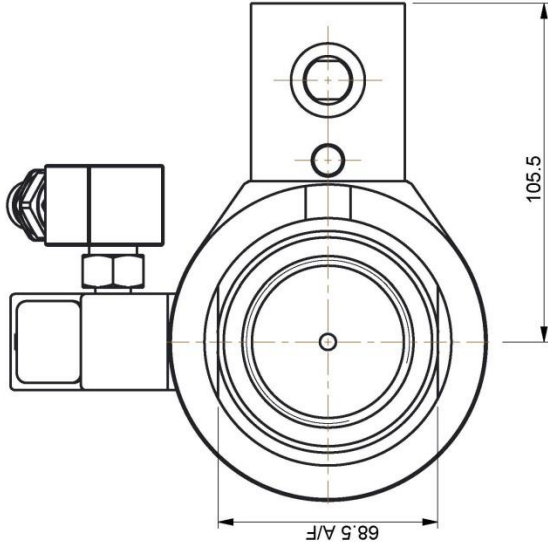
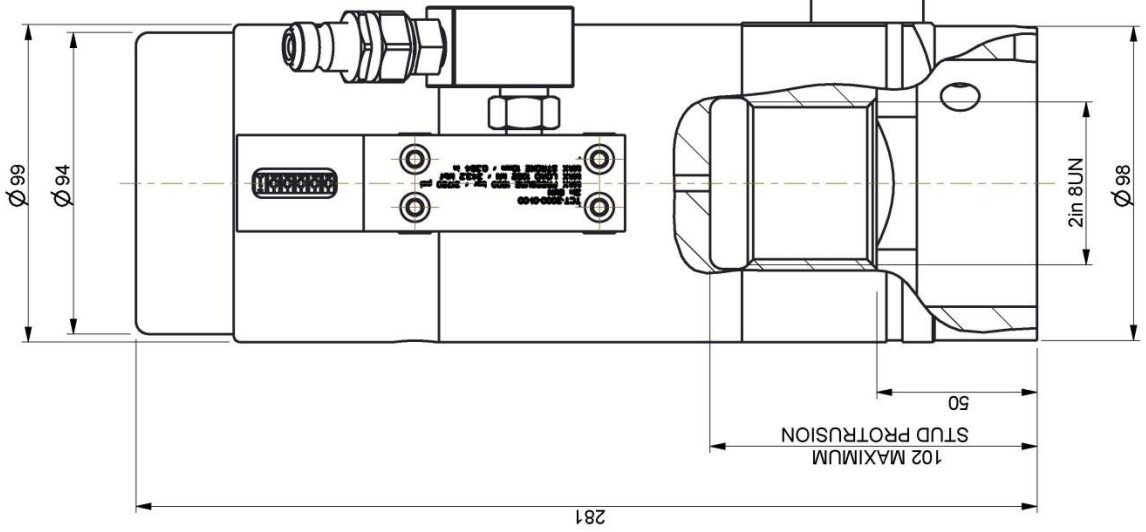

VIEW SHOWING BRIDGE PROFILE

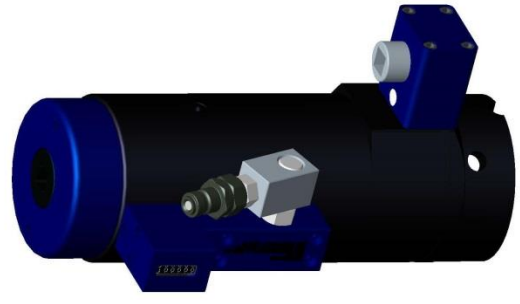

SCALE 0.400

TOOL FEATURES:

- OPTIONAL CYCLE COUNTER
- FAST SPRING RETURN
- OPTIONAL CARRYING HANDLE
- HIGH CYCLE FATIGUE LIFE
- SAFE FAILURE DESIGN
- ANTI-OVERSTROKE FACILITY
- LONG LIFE SEAL PERFORMANCE
- OPTIONAL NIPPLE/COUPLING CONFIGURATIONS
- LOW MAINTENANCE SPRING LOADED GEAR DRIVE

SPECIFICATION			
MAX WORKING PRESSURE	1500 bar	21750 psi	
MAX LOAD	1035 kN	232.7 klbf	
MAX STROKE	10 mm	0.394 in	
APPROX. TOOL WEIGHT	15 kg	33 lb	

MATERIAL																							
FINISH																							
SURFACE FINISH																							
LIMITS U.S.O.																							
SIZE	A3	SCALE	0.750	REV	A	CNN	-	JV	PJ	04/08/14	DRAWING NO.	HTCT-2000-21-00	ISSUE	A									
													2in 8UN MULTI-DECK CASING TENSIONER										

Max Cycles - 6000

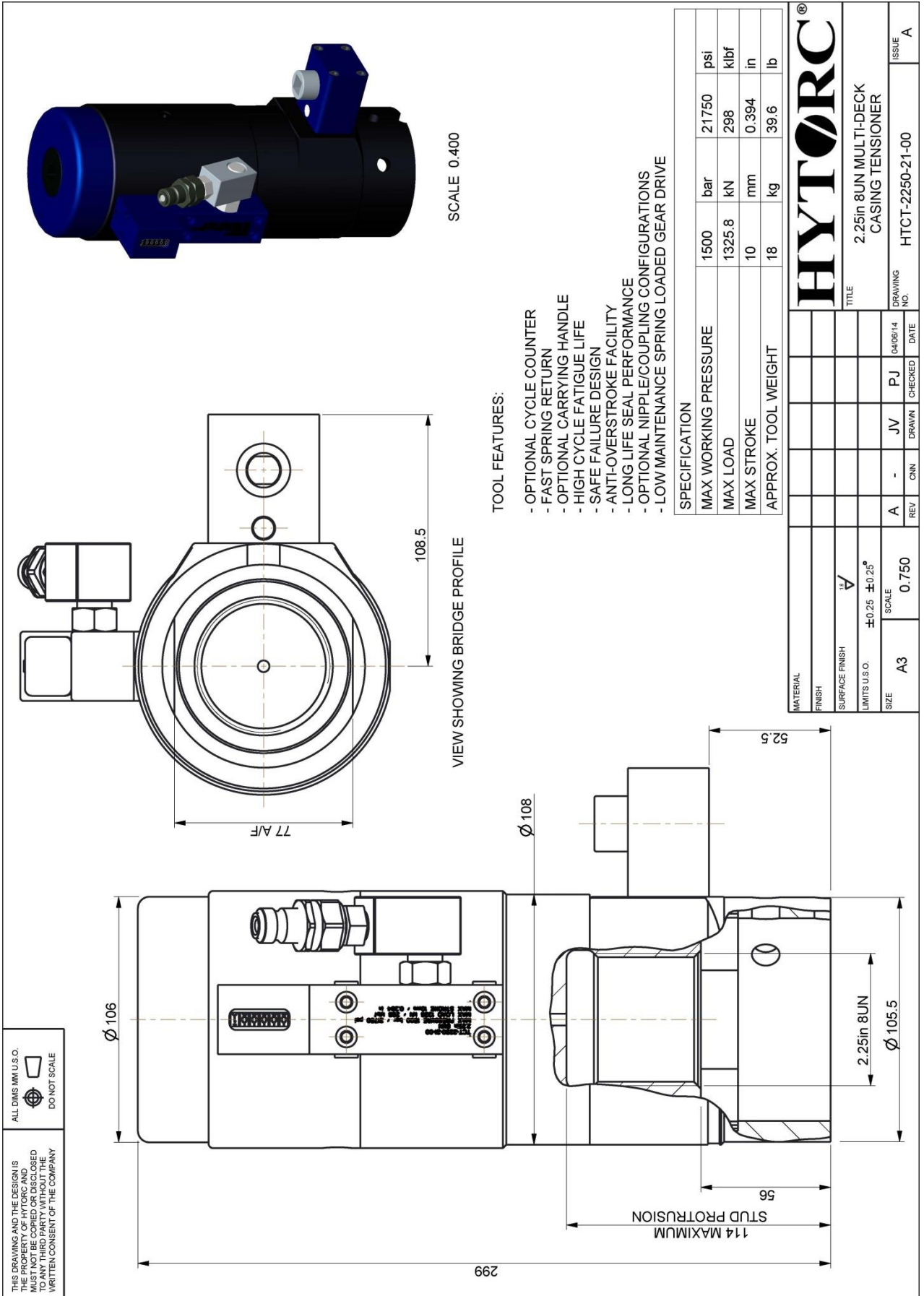

Oil Pressure Calculations

The formula used to calculate the Oil Pressure to be used with a bolt tensioning tool are given below along with definitions of the terms used :-

Bolt Load

Residual Bolt Load required when the tensioning operation is complete

Tensioning Force

The load that will be applied by the bolt tensioner during the tensioning operation

Load Loss Allowance

The ratio of ***Tensioning Force*** to ***Bolt Load***

$$\text{Load Loss Allowance} = \frac{\text{Tensioning Force}}{\text{Bolt Load}} = 1.01 + \left(\frac{\text{Bolt Diameter}}{\text{Grip Length}} \right)$$

If the ***Load Loss Allowance*** calculates to less than 1.10 then use 1.10.

$$\text{Tensioning Force} = \text{Bolt Load} \times \text{Load Loss Allowance}$$



Always check that the tensioning force will not exceed 90% of the yield strength of the bolt material. If it does, the grip length of the bolt must be increased. Contact HYTORC for advice on this.

$$\text{Oil Pressure (bar)} = \frac{10 \times \text{Tensioning Force (Newtons)}}{\text{Tool Pressure Area (mm}^2\text{)}}$$

Oil pressure graphs are provided for each bolt size.

The graph shows the theoretical tensioning force developed by the tool against the oil pressure applied.

Users who require highly accurate residual bolt stresses should perform a bolt extension measurement before and after tensioning. In this way residual bolt stresses can be calculated from the actual bolt extensions measured.

Tensioner Load / Pressure Graph

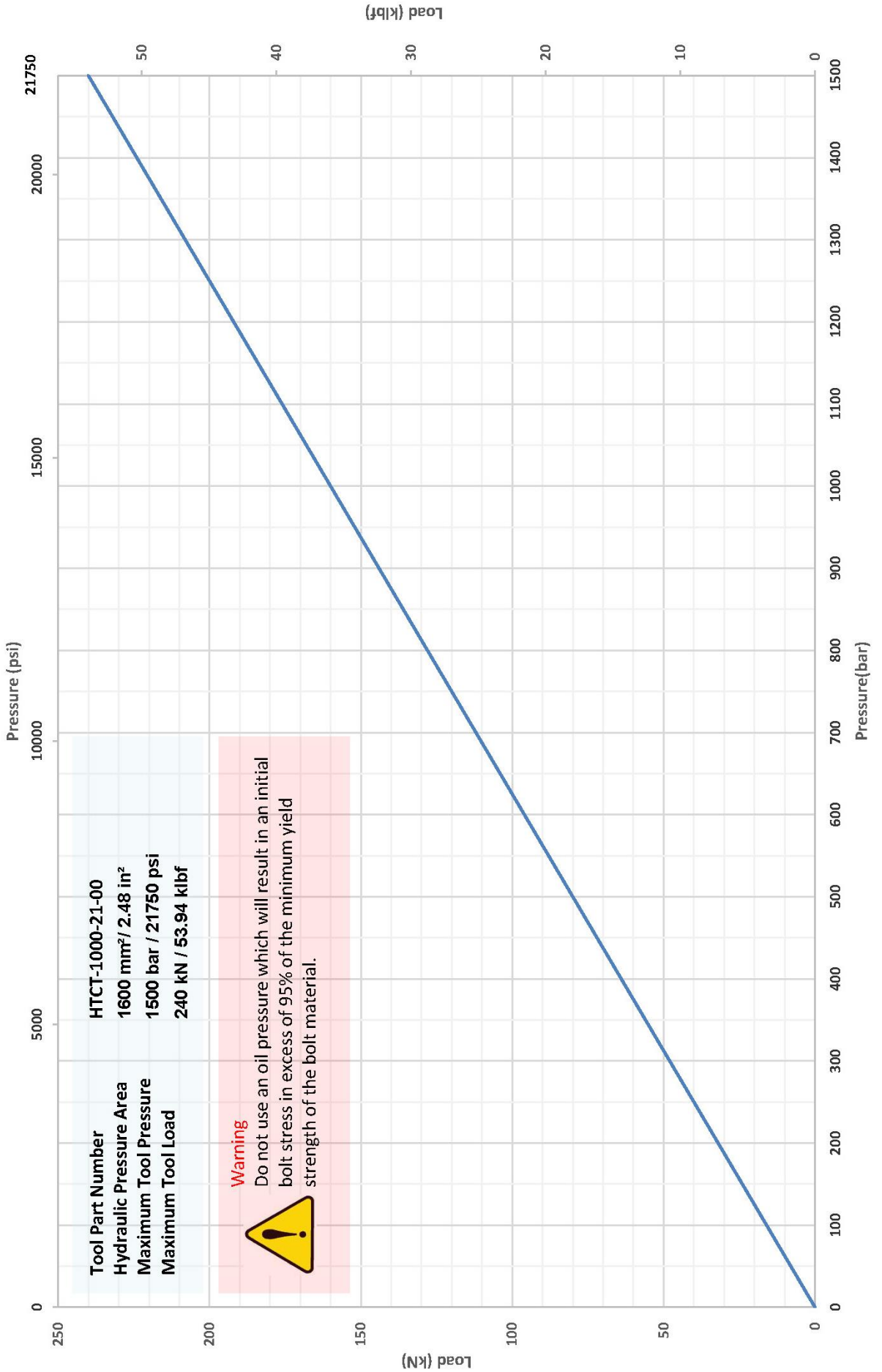

Tensioner Load / Pressure Graph

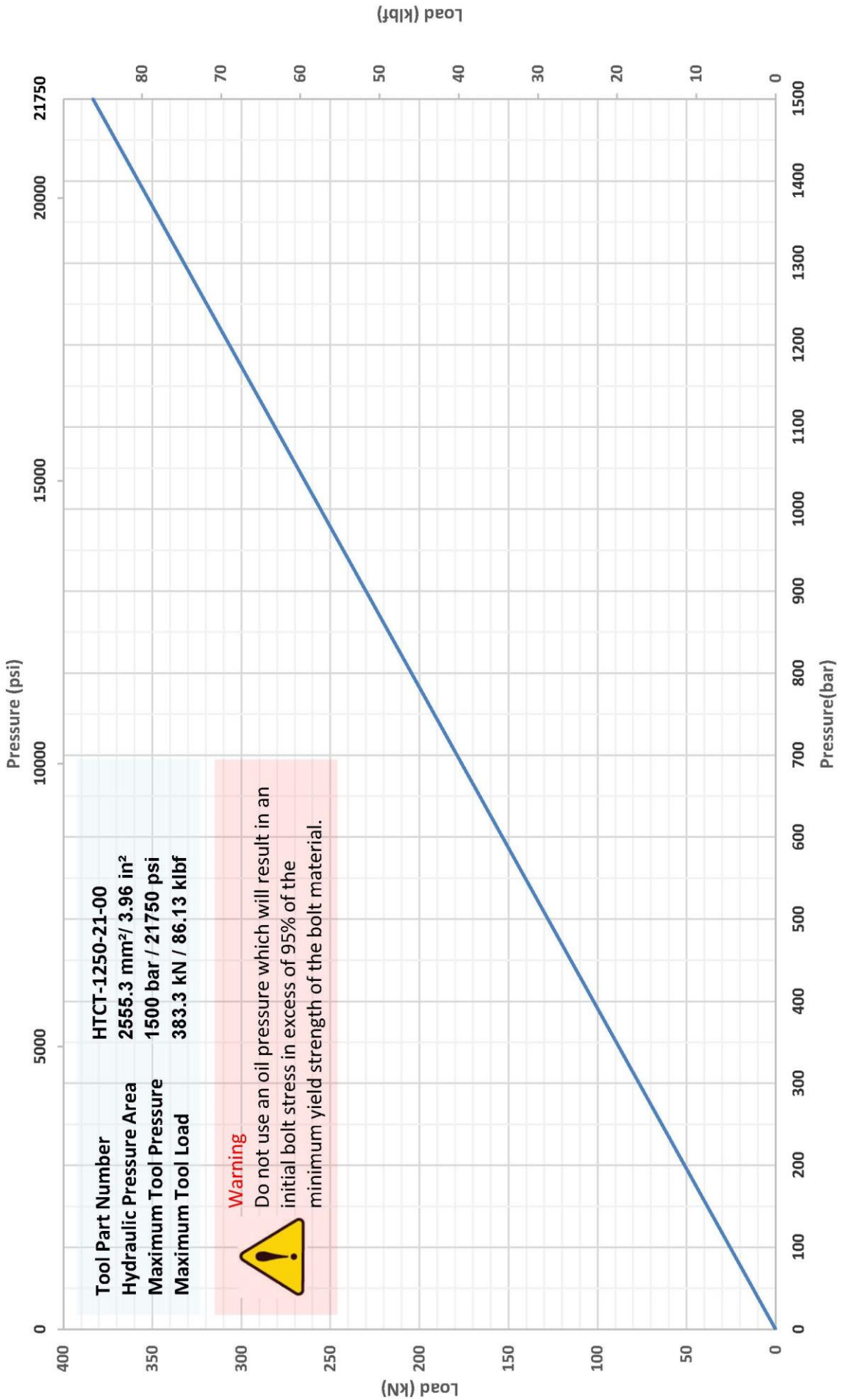

Tensioner Load / Pressure Graph

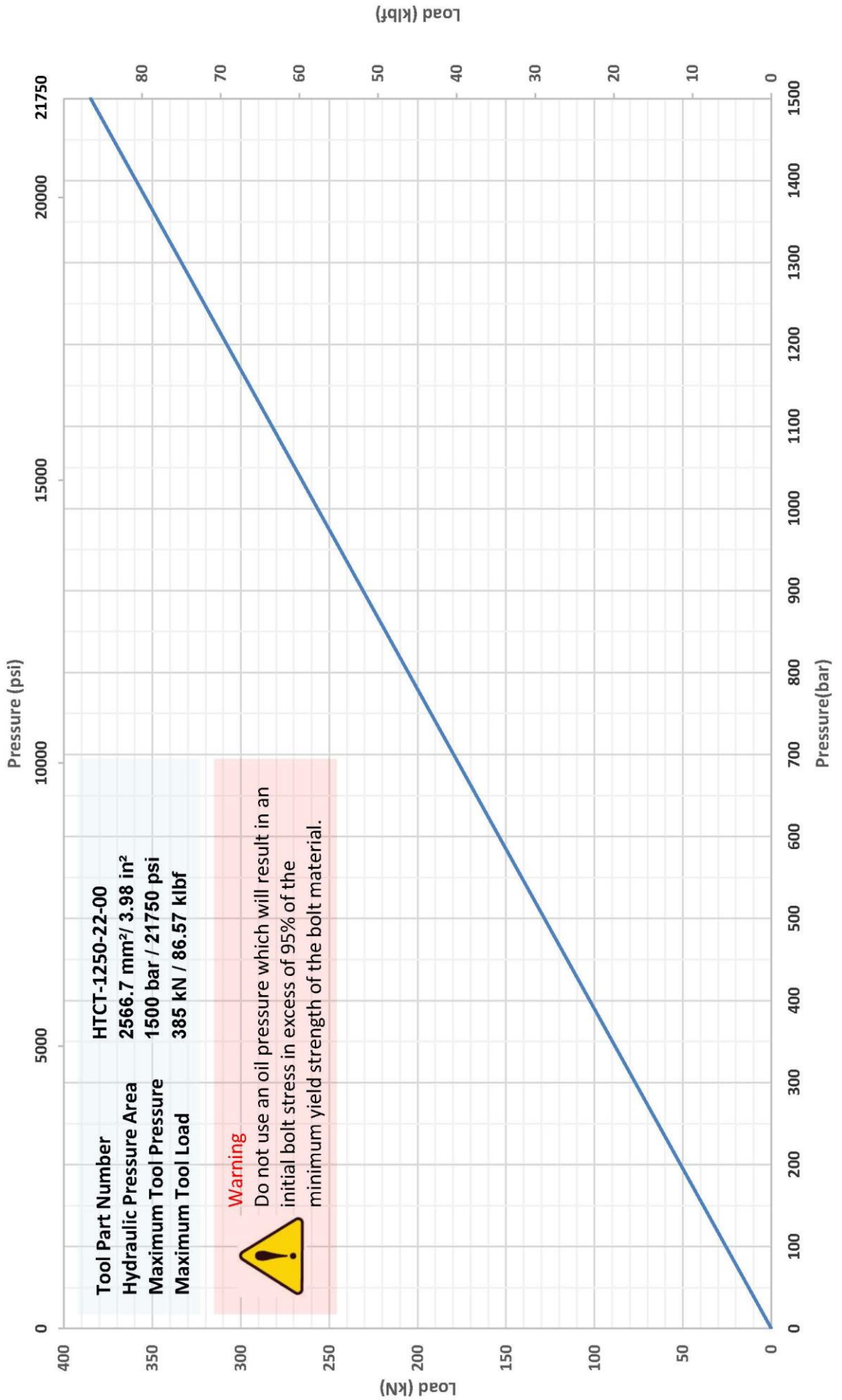

Tensioner Load / Pressure Graph

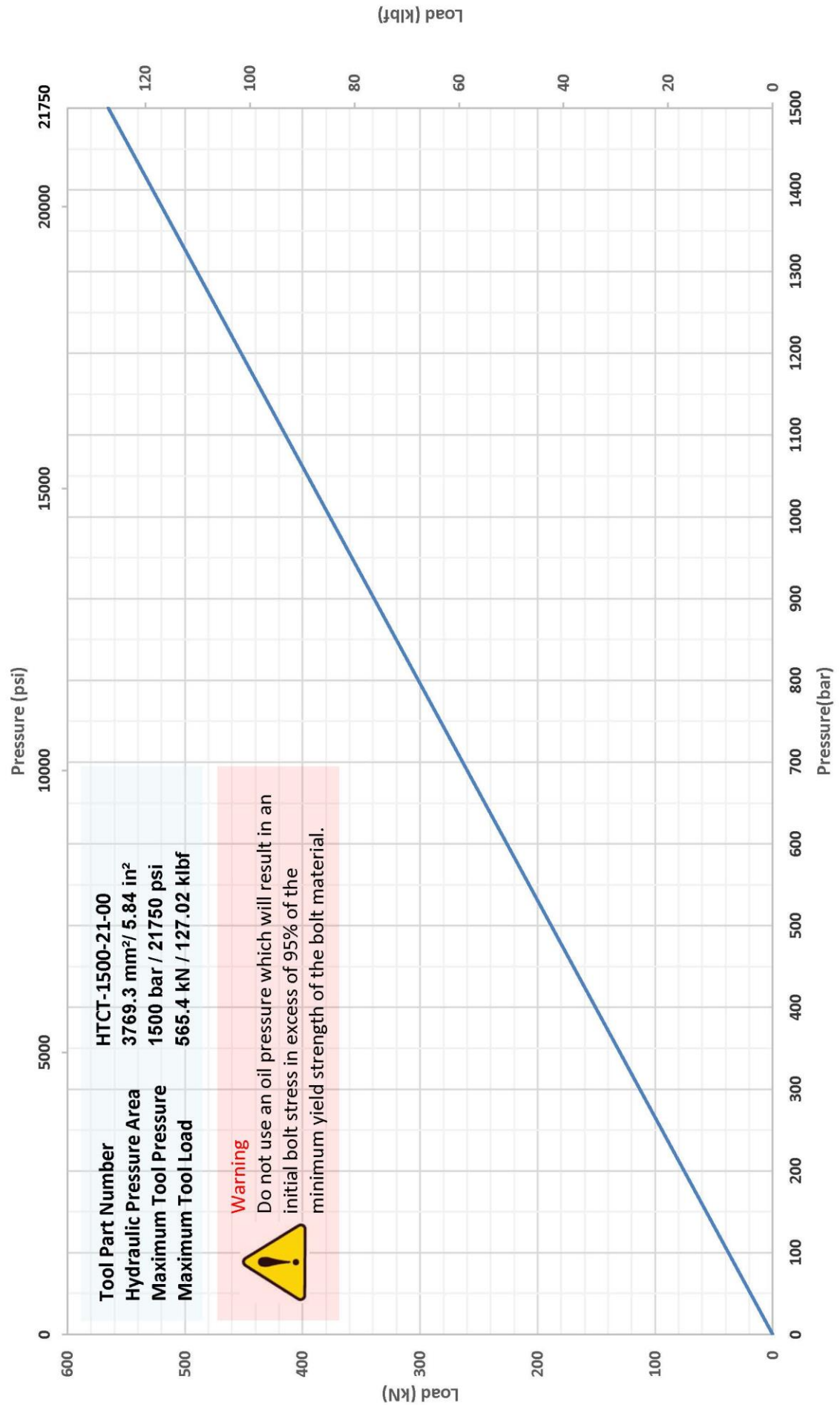

Tensioner Load / Pressure Graph

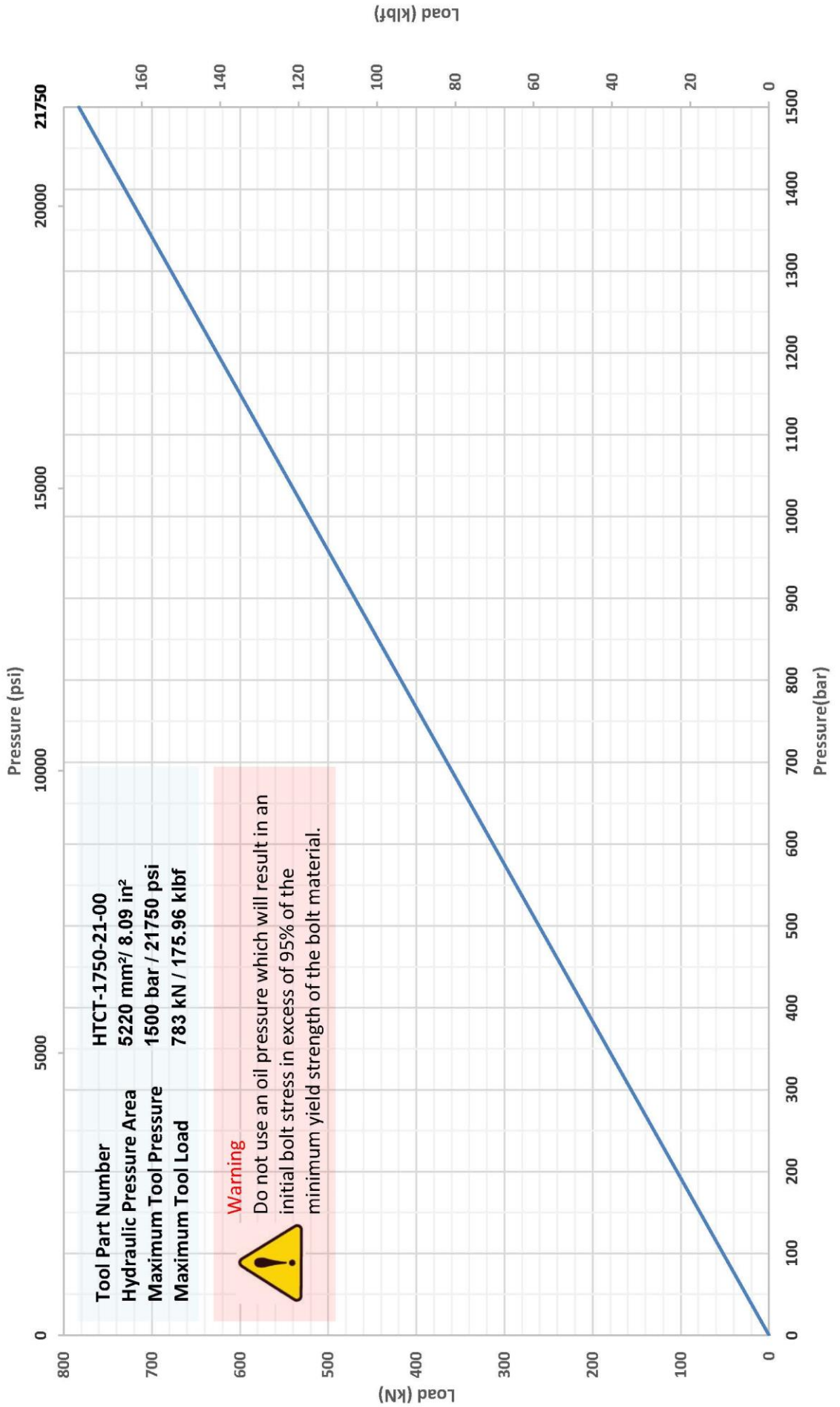

Tensioner Load / Pressure Graph

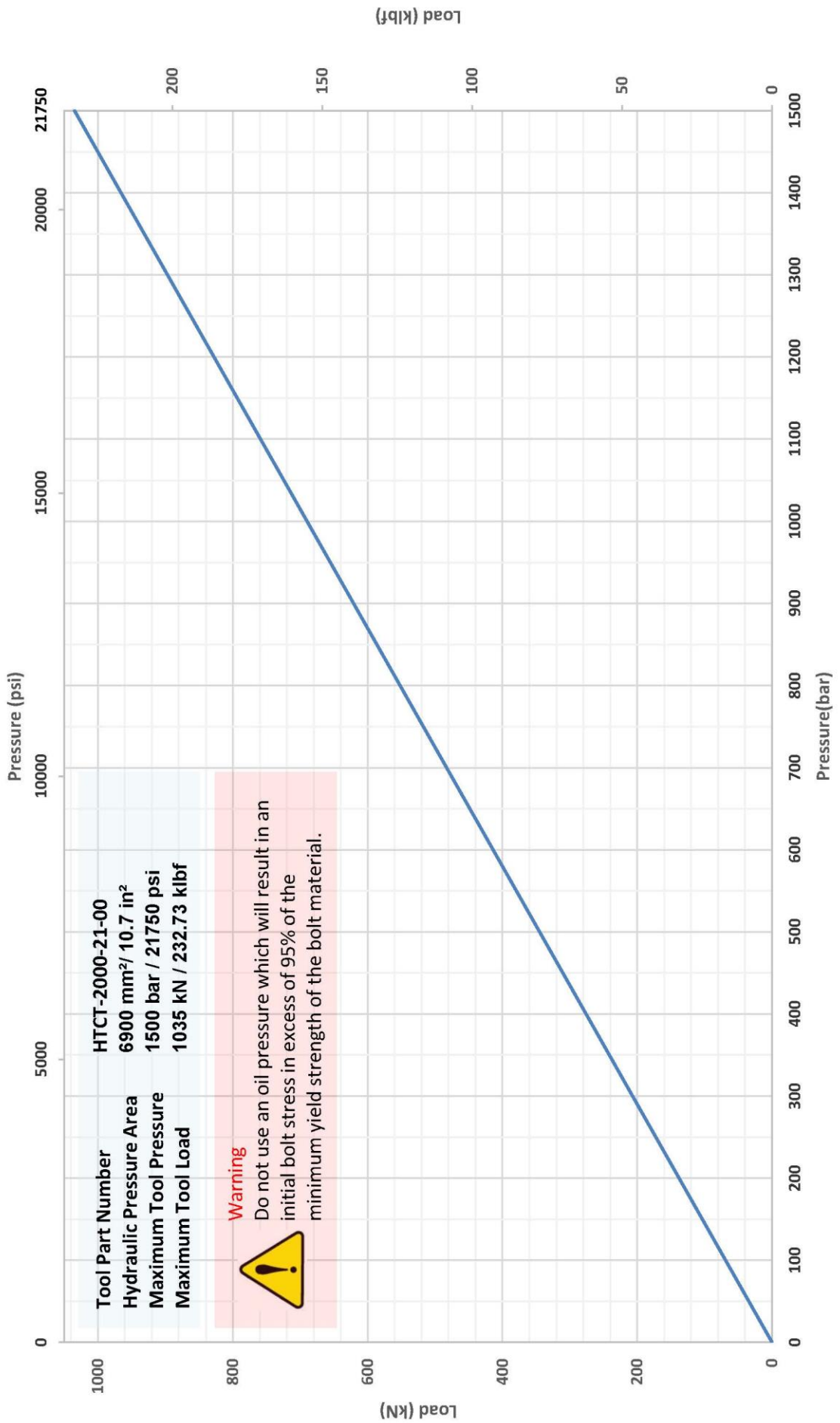

Tensioner Load / Pressure Graph

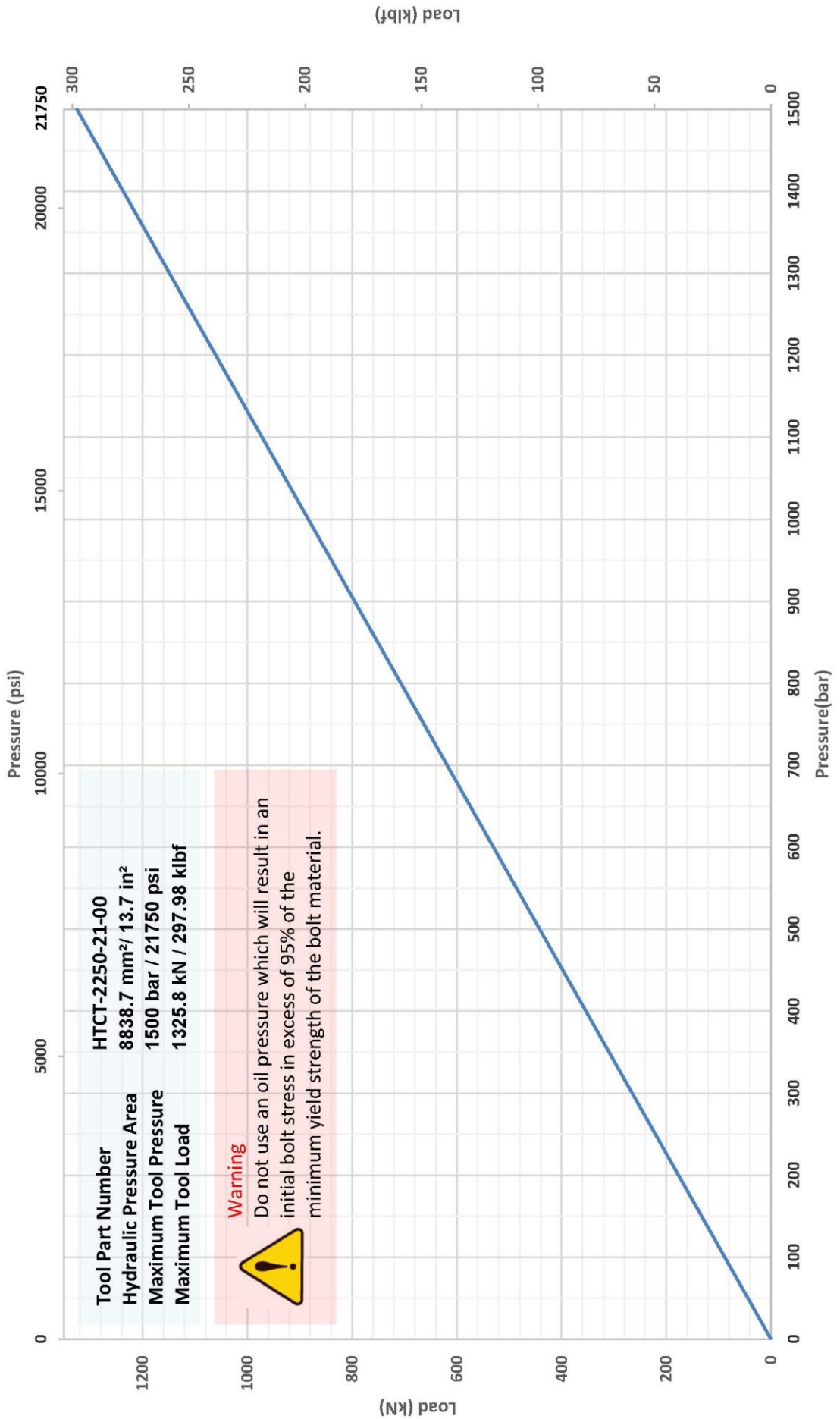

Section 6

Air Pump

HEALTH & SAFETY INSTRUCTIONS



You must observe the following Health & Safety instructions when using hydraulic hoses.

- Discard and do not use any hose that does not have an identifying serial number
- Discard and do not use any hose that shows any sign of damage either :-
 - a) to the coloured moulded plastic coating
 - b) where the spiral windings are exposed
 - c) where the spiral windings are damaged or broken
 - d) where there is damage to the swaged metal ends
- Do not allow any hose to be kinked or knotted. Hoses which have been kinked or knotted will have suffered damage to the windings and must be discarded.
- Do not allow heavy objects to fall on, rest on, or roll over the hoses.
- Do not allow hoses to be subjected to temperatures higher than 60 deg C.
- Discard and do not use any hose which has been subjected to heat or fire.
- Do not bend the hose tighter than the minimum bend radius of the hose or it will be kinked.
- Do not exceed the maximum working pressure of 1000 bar for the GREEN colour hose, 1500 bar for BLUE colour hose, and 2500 bar for RED colour hose.
- Only use the hoses for their intended purpose – for use with **HYTORC** hydraulic equipment.
- After use check the hoses for damage, wipe to remove dirt and oil, refit dust caps and prepare for storage.

- When not in use store the hoses in a safe place where they cannot easily be damaged.
- Do not mix the GREEN, BLUE , RED colour coded hoses. The end fittings and quick disconnect couplings on these hoses have different pressure ratings.
- Never move hose end connectors or quick disconnects from BLUE hoses to any other colour hose.
- Never move hose end connectors or quick disconnects from RED hoses to any other colour hose.
- Never move hose end connectors or quick disconnects from GREEN hoses to any other colour hose.
- Use GREEN colour coded hoses for 1000 bar System Tools and Equipment.
- Use BLUE colour coded hoses for 1500 bar System Tools and Equipment.
- Use RED colour coded hoses for 2500 bar System Tools and Equipment.
- Check the bolt tensioning tools you are using are compatible with the hoses you are using. All **HYTORC** tools are marked with the maximum operating pressure.
- Never pressurise a quick disconnect coupling or nipple when disconnected.
- Do not take apart any ring main harness component or hose assembly. These are filled with oil and pressure tested after assembly. When taken apart the integrity of the assembly is lost and the pressure test invalidated. Return any parts that need attention to HYTORC where the correct specification parts will be used to effect repairs, followed by pressure testing and certification before return.

Main Components

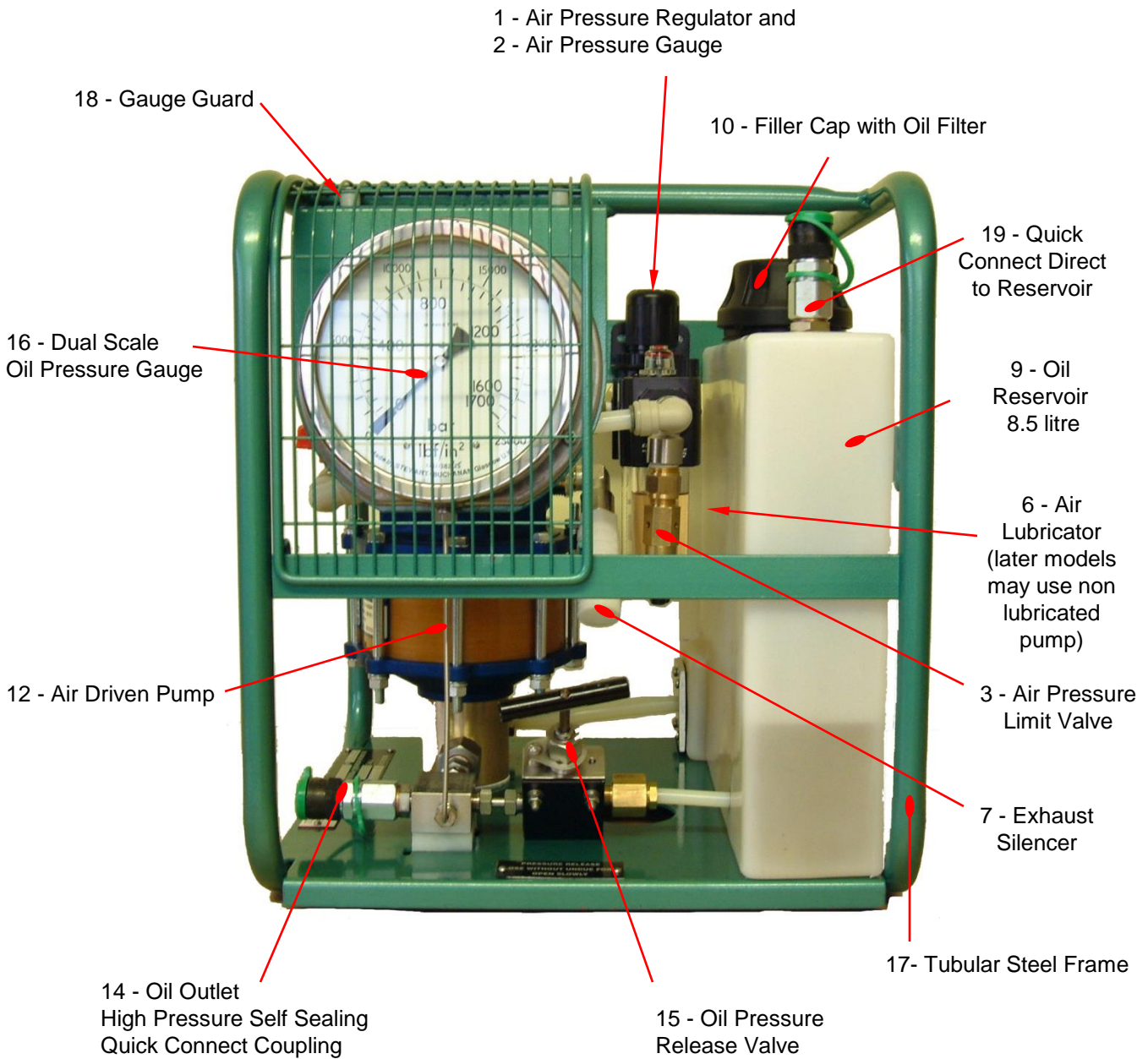

Front View

Main Components

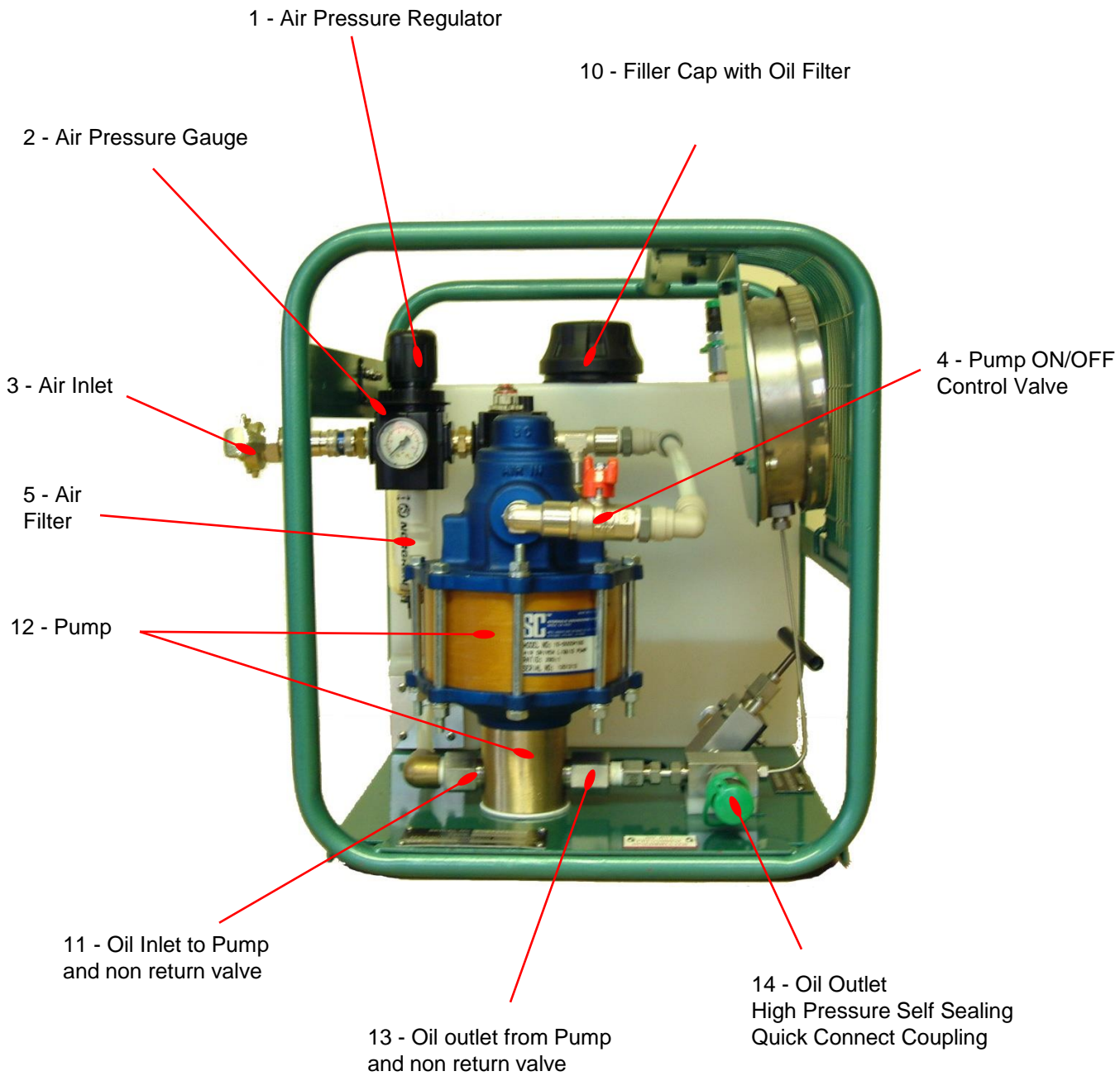

Side View

Main Components

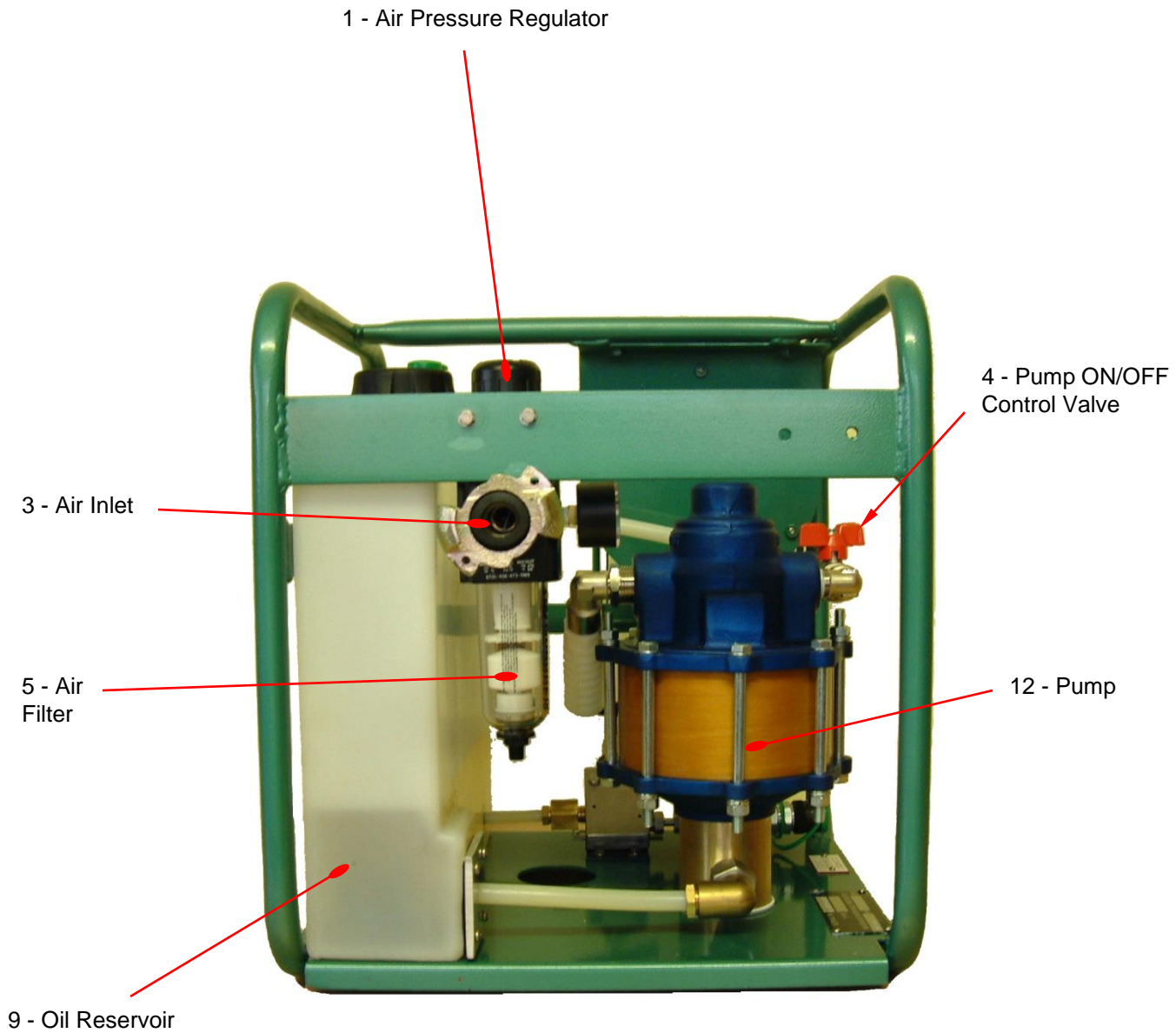

Rear View

Main Components

The numbers in brackets refer to the Front, Side and Rear Views.

1 - Air Pressure Regulator

The air pressure regulator controls the air pressure applied to the pump. To avoid accidental adjustment the cap has a locking mechanism. To unlock pull the cap upwards. To lock, push the cap down. When pulled up, rotate the plastic cap anti-clockwise to reduce pressure, and clockwise to increase air pressure. The controlled air pressure is displayed on the air pressure gauge (2). The controlled air pressure is limited by an air pressure limit valve (3).



2 - Air Pressure Gauge

Displays the controlled air pressure applied to the pump.



3 - Air Pressure Limit Valve

Limits the maximum air pressure applied to the pump and therefore limits the maximum oil pressure the pump can develop.



4 - Pump ON / OFF Valve

Starts and stops the pump by turning the controlled air ON or OFF. The picture on the right shows the valve in the OFF position. Turn through 90 degrees to turn fully ON and run the pump at maximum speed. The pump can be run slowly by partially opening this valve.



5 - Air Filter

The air filter is combined with the air pressure regulator (1). The filter bowl is beneath the air pressure regulator control cap. The filter removes dirt and water from the air supply. A drain valve at the base of the filter bowl can be opened to allow water to escape. When used with a wet air supply, the drain valve should be left open, just enough, to ensure the continual removal of all water entering the filter. The drain valve can remain closed when the air supply is always dry.



Main Components

6 - Air Lubricator

Provides oil mist lubrication for the pump. This is factory pre-set and should not need attention. The lubricator bowl is pre-filled with oil and should last a very long time. Later models use a new lubrication free air motor.



7 - Exhaust Silencer

When air has passed through the pump it exits the exhaust port of the pump through a plastic silencer. The silencer should require no maintenance.



8 - Air Inlet

The air inlet is through an industry standard bayonet connector. The connector can be easily unscrewed and changed if it does not match the fittings in use at the customers premises.



9 - Oil Reservoir

A large 8.5 litre plastic oil reservoir is provided. Oil is gravity fed to the pump from the base of the reservoir through a fine filter which should not require maintenance. Oil returns to the reservoir from the Oil Pressure Release Valve (15). A quick disconnect nipple is provided on the top of the reservoir. This is used if it becomes necessary to fill or bleed any of the hydraulic hoses.



10 - Filler Cap with Oil Filter

A large black plastic filler cap is removed by turning anti-clockwise and replaced by turning clockwise. Immediately beneath the filler cap, in the mouth of the reservoir, is a coarse oil filter. This can be easily lifted out for cleaning. The oil filter must be in place when filling the reservoir.



Main Components

11 - Oil Inlet to Pump and Non Return Valve

Oil enters the pump from the reservoir through a spring loaded Non Return Valve. This valve should not require attention. If problems arise with any of the non return valves it is best to return the pump to HYTORC for service. Overseas customers may have a local SC pump distributor who can carry out maintenance on these parts.



12 - Pump

The pump is manufactured by SC Hydraulic Engineering Corporation and is very robust and reliable. If used as directed the pump should not require maintenance for many years. If problems arise with the pump itself it is best to return the complete package to HYTORC for service. Overseas customers may have a local SC pump distributor who can carry out maintenance on the pump.



13 - Oil Outlet and Non Return Valve

Oil leaves the pump under pressure through a spring loaded non return valve. This valve should not require attention. If problems arise with any of the non return valves it is best to return the pump to HYTORC for service. Overseas customers may have a local SC pump distributor who can carry out maintenance on these parts.



14 - Oil Outlet - High Pressure Self Sealing Quick Connect Coupling

From the pump and non return valve, high pressure oil enters a 4 way distribution block. (one inlet and three outlets). One outlet feeds the oil pressure gauge(2). Another outlet goes directly to the Oil Pressure Release Valve (15). The final outlet is fitted with a self sealing quick connect coupling to which the hydraulic hose feeding the bolt tensioning tools must be connected. The coupling has a plastic dust cover which should be replaced when the pump is not in use. The pump should not be pressurised when the coupling is disconnected. A blank Quick Connect Nipple must be fitted to the coupling if the pump is to be pressurised.



Main Components

15 - Oil Pressure Release Valve

This high pressure valve should be treated with care. It is opened by turning the T shaped handle anti-clockwise. It is closed by turning the handle clockwise. The pump cannot generate any pressure when the valve is open as oil is free to circulate to the Oil Reservoir (9). When closing the valve care must be taken. Excess tightening will damage the high pressure valve seat. Care is also needed when opening the valve under pressure. Open slowly allowing the pressure to fall gently.

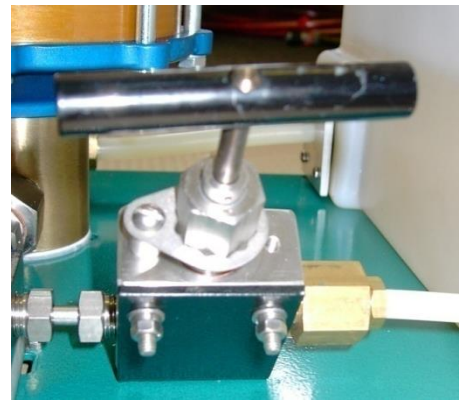

16 - Oil Pressure Gauge

All pump units are fitted with damped pressure gauges. The 1000 bar systems use a gauge calibrated to 1700 bar, the 1500 bar systems use a 2000 bar gauge and the 2500 bar systems use a gauge calibrated to 3000 bar. The reciprocating pump causes pressure pulses which are damped by the gauge to display a steadily rising or falling indication during pump operation.



17 - Tubular Steel Frame

All of the pump components are mounted in an easily transported, fabricated steel tube, carrying frame. The frame is painted GREEN for 1000 bar systems, BLUE for 1500 bar systems and RED for 2500 bar systems. The colours match the colour of the flexible hoses for these systems. Only use GREEN hoses with a pump painted GREEN, BLUE hoses with a pump painted BLUE and RED hoses with a pump painted RED. Do not mix the hoses and pumps.



18 - Gauge Guard

A metal grille is provided to protect the glass face of the pressure gauge.

19 - Quick Connect Direct to Reservoir

A quick connect coupling is provided directly onto the top of the Oil Reservoir. This can be used to bleed air from hoses and Ring Mains by connecting one end to the pump outlet and the other to this coupling. The connector can also be used to by-pass the Oil Pressure Release Valve during the bolt tensioner piston return operation. The hose is simply removed from the outlet and connected directly onto the tank. The bolt tensioner pistons will then be much easier to return.



How the Pump Works.

The air driven pump unit is a reciprocating pump / intensifier. A large diameter piston reciprocates under air pressure of 4 bar to 6 bar and is attached to a much smaller diameter piston which generates oil pressures between 1000 bar, 1500 bar and 2500 bar depending on the model of pump.

An air flow and oil flow chart on the next page shows the movement of both air and oil through the air driven pump unit.

Air Side

Air enters the pump through the bayonet air inlet (8), and passes immediately to the air filter (5) and air pressure regulator (1). The air pressure regulator controls the pressure from the air inlet which is allowed to act on the air piston of the pump. Increasing the air pressure on the air piston will increase the oil pressure generated at the oil piston. The air pressure at the air piston is indicated on the air pressure gauge (2). From the air pressure gauge the air passes through an oil mist air lubricator (6) which provides a small amount of lubrication for the air piston seals. Later models may use a lubrication free air motor. Air then passes an air pressure limit valve (3). This valve is spring loaded and has been factory set to limit the air pressure which can be applied to the piston. From the air pressure limit valve the air passes to the air piston via the pump ON / OFF Control Valve (4). Fully opening this valve allows the pump to run at full speed. This valve can be used to throttle the air passing to the air piston causing the pump to run more slowly. The air arriving at the air piston forces it down generating oil pressure on the oil side of the pump. At the end of its downward power stroke a series of valves and springs causes the piston to return to the top of its cylinder ready for the next power stroke. During the return stroke the used air is released to the atmosphere through an exhaust silencer.

Oil Side

Oil enters the oil reservoir through the filler cap (10), passing immediately through a coarse oil filter. Oil is retained in the oil reservoir (9). Gravity causes the oil to pass through a fine filter at the base of the reservoir before arriving at the oil pump inlet. As the air and oil piston assembly rises, oil is drawn into the oil cylinder through an oil inlet non return valve (11). When the piston falls under the power stroke the oil is compressed and forced out of the oil cylinder through the oil outlet non return valve (14). The oil enters a high pressure distribution block where its return to the reservoir is blocked by the oil pressure release valve (15), when closed. If the oil pressure release valve (15) is open, oil is simply recycled to the reservoir (9). As long as the pump ON/OFF Control valve (4) remains open the pump will run sending oil around the oil circuit and back to the reservoir (9) but never achieving any increase in oil pressure. As soon as the oil pressure release valve (15) is closed the oil cannot return to the reservoir and oil pressure will be developed in the high pressure distribution block. The high pressure distribution block feeds oil pressure to the oil pressure gauge (16) which indicates the pressure generated. The oil pressure gauge (16) is damped to ensure a steady reading during the pressure pulses generated by the reciprocation of the pump(12). Oil passes from the pump unit through the oil outlet high pressure self sealing quick disconnect coupling (14). The bolt tensioning equipment is connected to this coupling. Oil passes to the bolt tensioning tools and the pressure generated by the pump acts on all of the tools simultaneously. The pressure generated is indicated on the oil pressure gauge (16) at all times.

Pump Stall

When the pump is working and generating an increasing oil pressure the pump will eventually begin to slow down until a stall situation arises. At this point the pump will stop and the oil pressure will be maintained. If the oil pressure starts to fall, for any reason, the pump will restart until the stall pressure has been achieved again. This stall will happen when the force on the air piston equals the force on the oil side of the piston. The stall oil pressure is effectively set by the air pressure regulator (1). A higher air pressure will result in a higher oil pressure stall and a lower air pressure will result in a lower oil pressure stall. This phenomenon of stall allows the operator to pre-set the pump to achieve a desired oil outlet pressure which cannot be exceeded. The air pressure limit valve (3) has been factory set to limit the maximum air pressure which can be applied to the pump and hence the maximum oil pressure the pump can generate.

How the Pump Works.

Air Side Flow Diagram

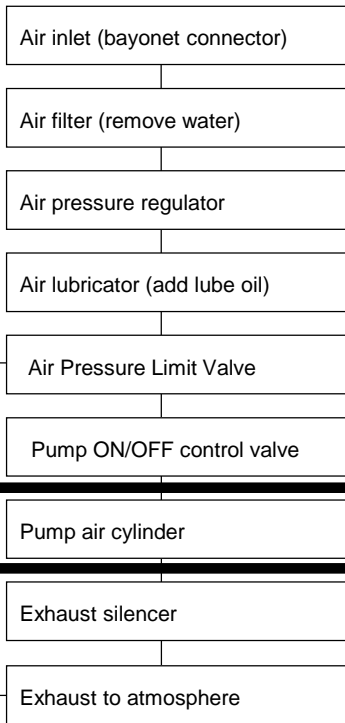
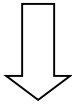

See note (a)

Note (a)
Later models may use an oil free air motor.

Oil Side Flow Diagram

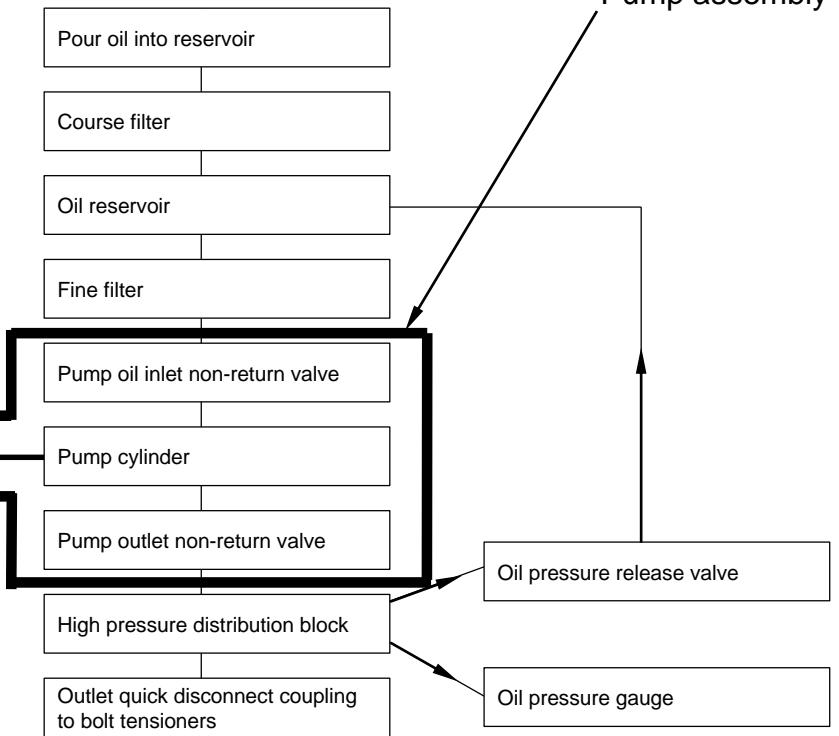
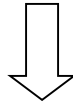
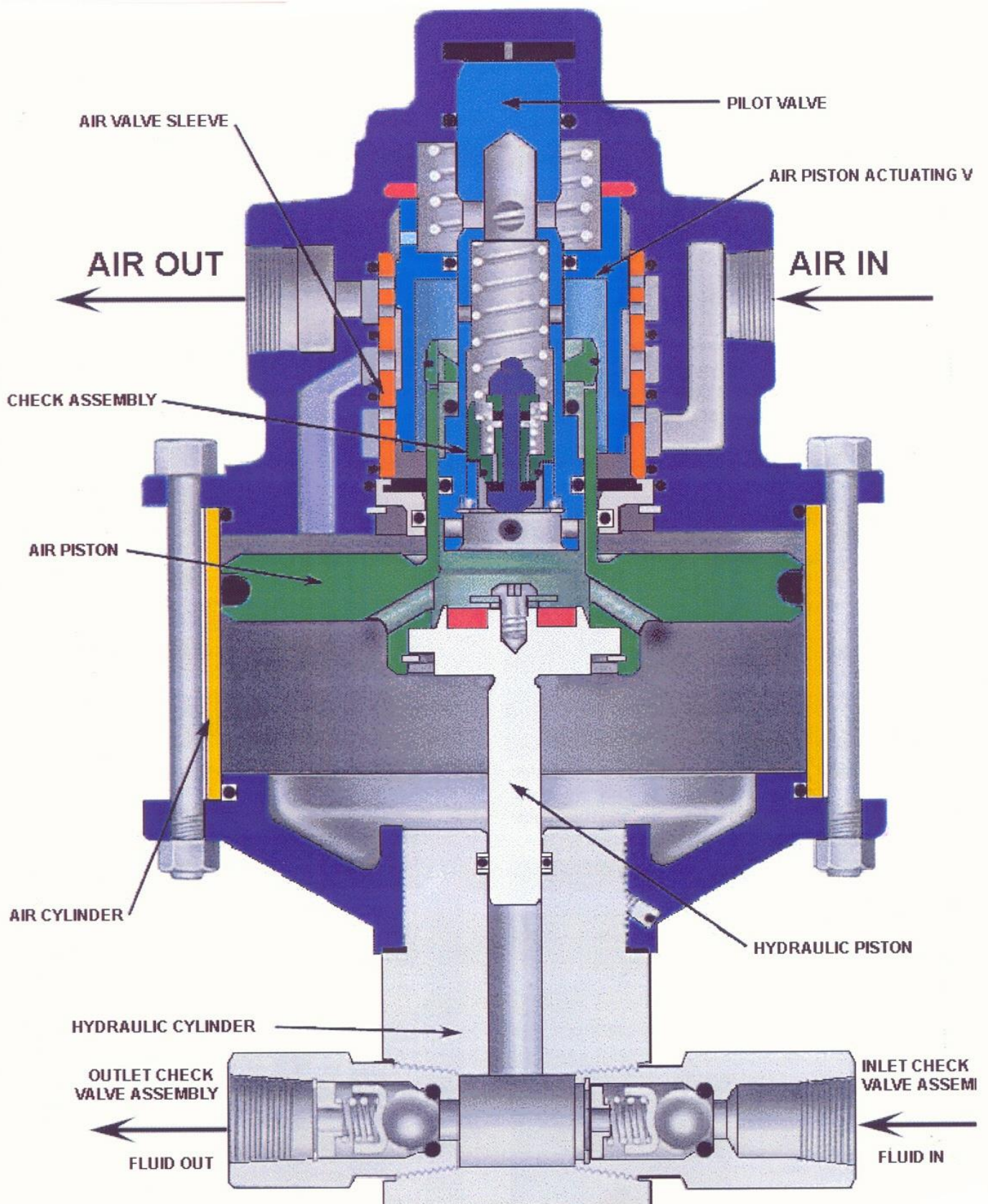

Figure 3

Sectional drawing of the Pump Assembly



SETTING UP THE PUMP

Step 1

If a packing case was ordered with the pump, carefully open the case and retain it for storing the pump when not in use. Remove the pump from the plastic bag.

Step 2

Check the air pressure inlet connection is compatible with the mains air supply you intend to use with the pump. If not fit the correct type of connector to the air inlet on the pump unit.



Step 3

Remove the oil filler cap from the oil reservoir. Do not remove the coarse filter fitted beneath the filler cap. Pour ISO10 hydraulic fluid into the reservoir, through the coarse filter until it is about three quarters full. The reservoir takes about 8.5 litres of oil when full. Refit the oil filler cap.



Step 4

Check the air lubricator to see if it is filled with lubricating oil. If not locate the lubricating oil supplied with the pump and fill the lubricator to the maximum level marked on the bowl. Do not attach the mains air before the lubricator is filled. If the mains air supply has been attached you must remove it before attempting to fill the oil lubricator.



Step 5

Fully open the Oil Pressure Release Valve. Turn the handle ant-clockwise to open the valve.

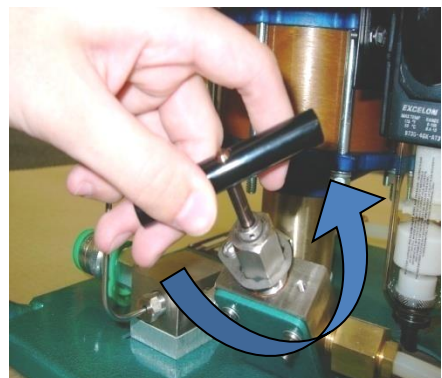

SETTING UP THE PUMP

Step 6

Close the pump ON/OFF control valve. Turn the handle a quarter turn clockwise to close the valve.

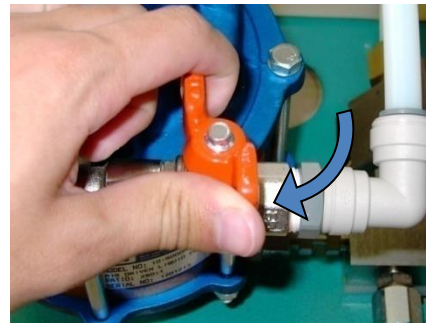

Step 7

Connect the mains air supply (70 -100 psi 5 - 7 bar).

Step 8

Check the regulated air pressure gauge.

Regulated Air
Pressure
Gauge

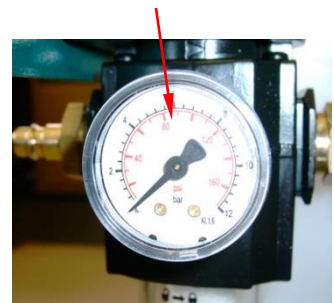

If it is not zero, Lift the black cap to unlock it and turn the air pressure regulator anti clockwise until the regulated air pressure falls to zero.



Step 9

Open the pump ON/OFF valve. Turn the handle a quarter turn anti-clockwise to open the valve.



SETTING UP THE PUMP

Step 10

Slowly turn the air pressure regulator clockwise until the pump runs at a speed between 30 and 60 strokes per minute.

Leave the pump to reciprocate for two minutes to bleed all of the air from the pump and pipe-work.



Step 11

Observe the air lubricator (if fitted). This has been factory set to lubricate the air supply at the rate of one drop of oil for every fifty strokes of the pump.

A red plastic knob is provided for adjustment if and when necessary.



Step 12

Stop the pump by closing the pump ON/OFF control valve.

The pump is now ready for use. Proceed by first setting the pump stall pressure as described in Section 6 of this manual.



SETTING THE PUMP STALL PRESSURE

The air driven pump can be set to stall at any pre-determined pressure. This is a safety feature which, prevents the operator from inadvertently exceeding the maximum working pressure for the bolt tensioning equipment.

Setting the stall pressure is achieved by adjusting the regulated air pressure which is allowed to drive the pump. To set the pump stall pressure first set up the pump as described earlier in this manual, ensure the oil reservoir has a good supply of oil and connect the pump to a suitable air supply.

With the pump ready for operation proceed as followings:-

Step 1 Attach a blank quick connect nipple to the oil pressure outlet coupling.

The oil outlet quick connector must not be pressurised whilst it is disconnected.

To set the stall pressure the oil pressure must be increased so a quick connect nipple with a blank end must first be fitted to the outlet connector.

The Health and Safety Section gives instructions for the connecting and disconnecting of these fittings.

To fit the blank quick connect nipple, pull back the spring loaded collar on the oil outlet coupling, push the nipple into the coupling and release the collar.

Check the nipple is properly connected before proceeding.

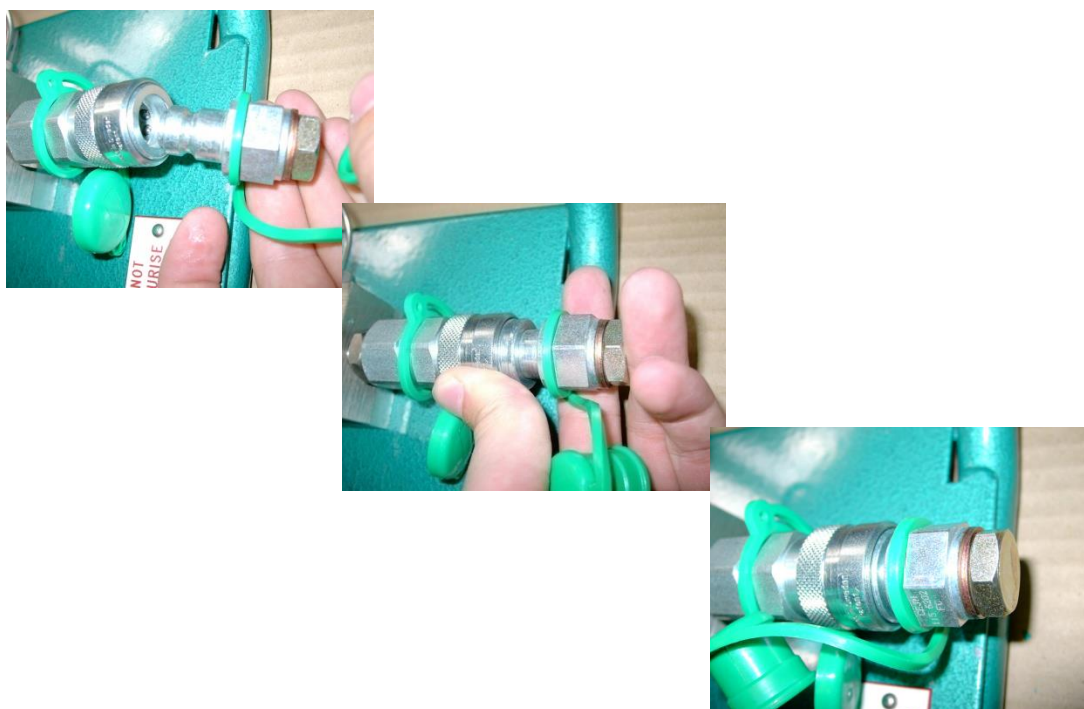

SETTING THE PUMP STALL PRESSURE

Step 2 Close the Pump ON/OFF control valve.

Turn the valve clockwise to close the valve



Open

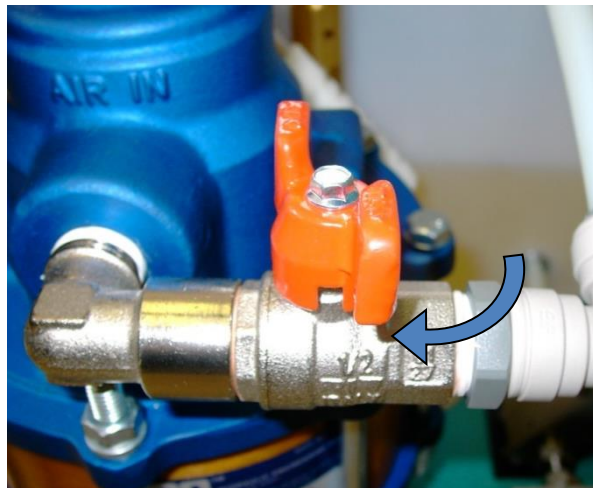

Closed

Step 3 Unlock the air pressure regulator cap.

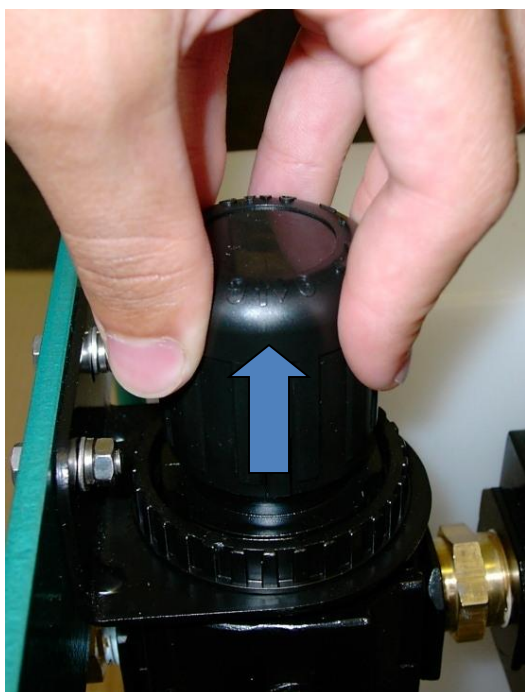

The air pressure regulator has a black cap. The cap is locked by pushing it down and unlocked by lifting it up.

Unlock the cap by lifting it.

SETTING THE PUMP STALL PRESSURE

Step 4 Reduce the regulated air pressure to zero.

Turn the air pressure regulating cap anti-clockwise to reduce the regulated air pressure. Observe the regulated air pressure gauge. Stop turning the air pressure regulator when the regulated air pressure gauge is reading zero bar.

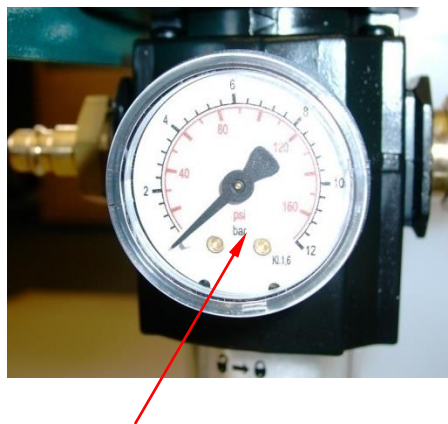

Regulated Air Pressure Gauge

Step 5 Close the oil pressure release valve.

Turn the handle on the oil pressure release valve (15) clockwise until the valve is closed. Do not over tighten this valve otherwise the seat can be damaged.

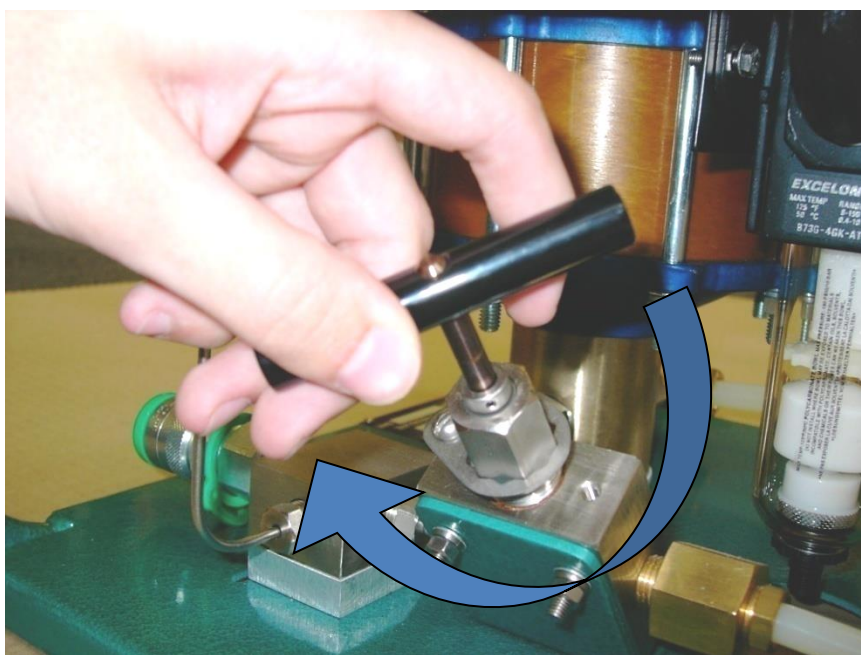

SETTING THE PUMP STALL PRESSURE

Step 6 Open the pump ON/OFF control valve.

Turn the pump control valve anti-clockwise to open it. The pump will not start at this point because the regulated air pressure has been reduced to zero bar.



Closed

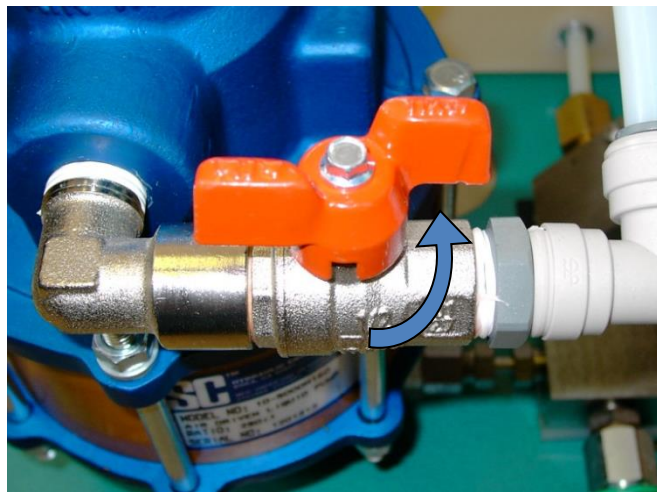

Open

Step 7 Slowly increase the regulated air pressure

Turn the air pressure regulator clockwise to increase the regulated air pressure. Turn the regulator slowly. As soon as the air pressure starts to increase the pump will run. Because of the small volume of oil under pressure, the pump will quickly stall. The stall pressure will now be seen on the oil pressure gauge.

Continue to turn the air pressure regulator until the desired stall pressure is indicated on the oil pressure gauge.



SETTING THE PUMP STALL PRESSURE

Step 8 Lock the the air pressure regulator.

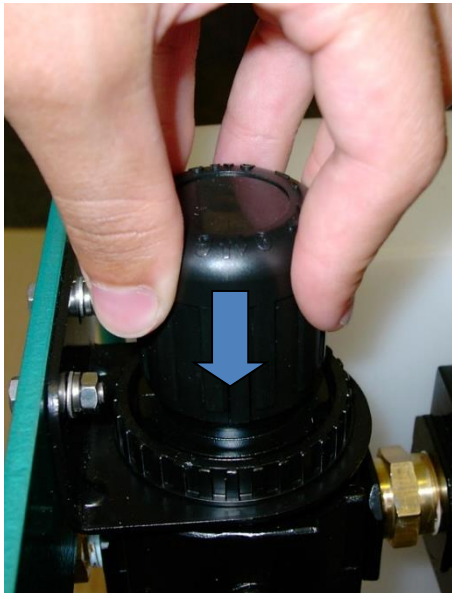

Lock the air pressure regulator cap .
Push the cap down to lock it.

The oil pressure gauge continues to
indicate the stall pressure.



Step 9 Close the pump ON/OFF control valve.

Turn the pump control valve anti-clockwise to close it.

The pump has already stalled so there will be no immediate or noticeable
reaction to the closing of the ON/OFF control valve.

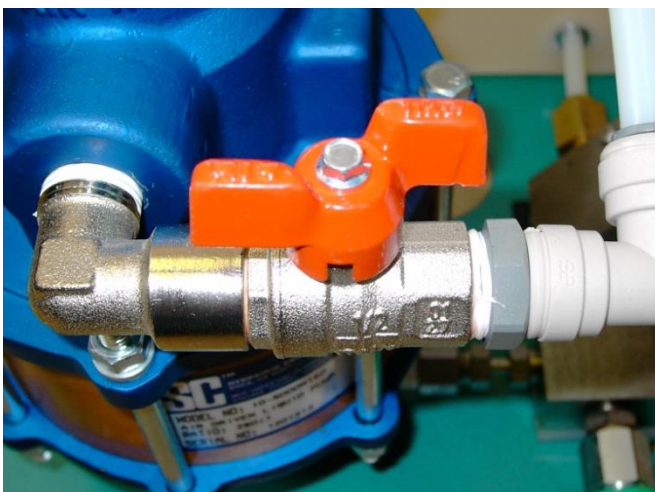

Open



Closed

SETTING THE PUMP STALL PRESSURE

Step 10 Slowly open the oil pressure release valve.

Slowly turn the handle on the oil pressure release valve anti-clockwise until the valve is fully open.

The oil pressure will quickly fall to zero bar.

The pump has now been set to stall at the pre-determined oil pressure. When in use the pump will not increase the pressure above the stall pressure now set.



This assumes a constant air pressure supply to the pump. If there are large variations in the supply air pressure, the pump may stall at a lower or higher pressure than the stall pressure setting.

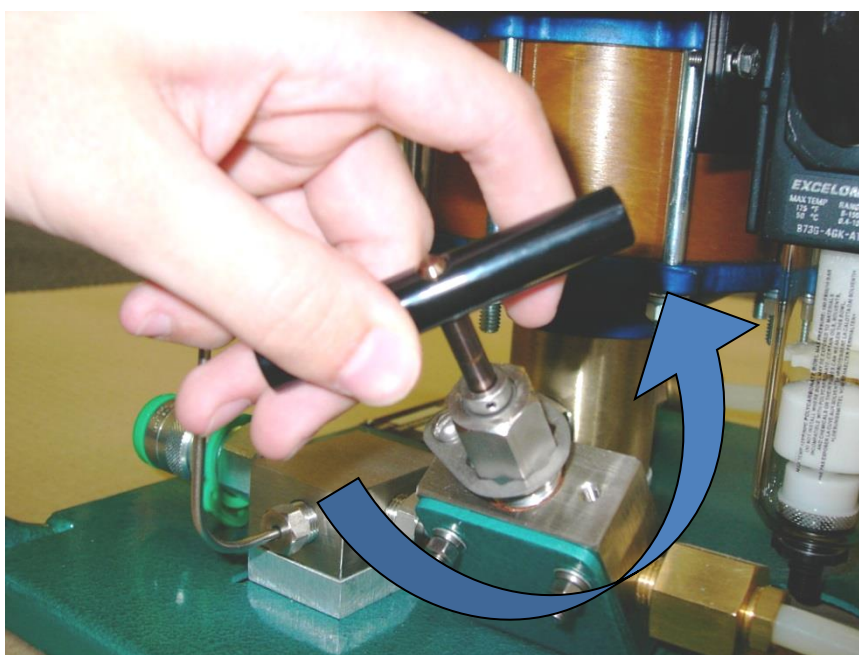

OPERATING THE PUMP

Step 1 - Follow the instruction under SETTING UP THE PUMP as described from page 16 of this section of the manual.

Step 2 - Follow the instructions under SETTING THE PUMP STALL PRESSURE from page 19 of this section of the manual. Set the stall pressure of the pump to match the operating pressure of the equipment to be used.

Step 3 - Connect the equipment to be pressurised to the quick connect coupling on the outlet of the pump unit. Follow the instructions for using the quick connect couplings as described on page 5 of this section of the manual.

Step - 4 Close the Oil Pressure Release Valve.

Step - 5 Check all of the quick connect couplings on the hydraulic hoses and tools are correctly connected and ready to be pressurised.

Step - 6 Start the pump by opening the Pump ON/OFF control valve.

Step - 7 The pump will run and pressure will build up. The speed of the pump can be regulated by how much the pump ON/OFF valve is opened.

The oil pressure will be indicated on the oil pressure gauge. The pump will run until the pressure reaches the stall pressure setting. To stop the pump before reaching the stall pressure, close the pump ON/OFF control valve.

Step - 8 Stop the pump by closing the Pump ON/OFF control valve.

Step - 9 To release the oil pressure, with the pump ON/OFF valve closed, slowly crack open the Oil Pressure Release Valve. Allow the oil pressure to fall slowly to zero. When at zero pressure, fully open the valve.



IF ANY UNSAFE WORKING SITUATION SHOULD ARISE DURING THE OPERATION OF THE PUMP IMMEDIATELY FULLY OPEN THE OIL PRESSURE RELEASE VALVE AND THEN CLOSE THE PUMP ON/OFF CONTROL VALVE.

This will dump the oil pressure and stop the pump.

END OF DOCUMENT