



TSR+ AUTO RETURN TENSIONER

Features

INTERCHANGEABLE

TSR+ load cells have exactly the same overall dimensions and hydraulic specification as the existing TSR load cells. This ensures interchangeability and ease of customer upgrades to the new range.

DURABLE

Operational performance does not degrade during the life of the tool. TSR+ completed more than 10,000 full pressure/stroke cycles during in-house testing.

INCREASED SAFETY

TSR+ load cells have a relief valve to prevent accidental overstroke of the tool. This safety mechanism prevents seal blow outs and the users exposure to ejected oil.

PREMIUM SURFACE TREATMENT

All load cells have unique surface finish which provides a long lasting finish against harsh environments.

IMPROVED SEAL TECHNOLOGY

Latest design eases seal changeouts and enhances general performance throughout high cycle usage.

OPTIONS

- Twin port hydraulic connections
- Oversized Threads
- Geat Drive nut rotation
- Swivel connectors
- Special designs

The all new TSR+ Auto Return Tensioner range has been designed to ensure fast, simple, safe and reliable operation. With a focus on productivity and a reduction in downtime we have implemented state of the art materials and technology resulting in significant time saving during operation.

TECHNICAL AND DIMENSIONAL SPECIFICATION

Tensioner Design	Single acting cylinder, auto return
Maximum Operating Pressure	1500 bar (21750 psi)
Stroke	10mm (0.375 inches) except TSR+ O - 8mm (0.315 inches)
Hydraulic Oil Type	ISO 32 or equivalent

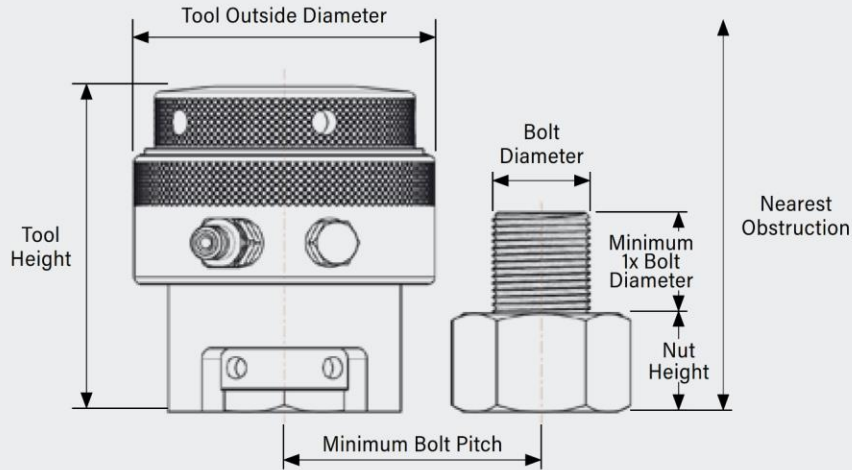

TOOL NUMBER	BOLT DIAMETER		HYDRAULIC AREA mm ²	MAXIMUM LOAD		TOOL OUTSIDE DIAMETER		TOOL HEIGHT		DISTANCE TO NEAREST OBSTRUCTION		TOTAL TOOL WEIGHT		LOAD CELL WEIGHT	
	in.	mm		lbf	kN	in.	mm	in.	mm	in.	mm	lbs	kg	lbs	kg
TSR+ 0*	3/4	M20	1,070	35,970	160	2.60	66	3.66	93	5.59	142	3.1	1.4	2.2	1
		M22						3.66	93	5.67	144				
TSR+ 1	1 1-1/8	M24	1,870	62,950	280	3.43	87	4.61	117	6.89	175	8.8	4	5.3	2.4
		M27						4.61	117	7.01	178				
		M27						4.72	120	7.01	178				
TSR+ 2	1 1-1/8 1-1/4 1-3/8	M24	3,000	101,160	450	4.06	103	4.61	117	6.89	175	12.8	5.8	7.3	3.3
		M27						4.61	117	7.01	178				
		M30						4.72	120	7.24	184				
		M33						4.84	123	7.48	190				
		M36						4.96	126	7.72	196				
TSR+ 3	1-1/4 1-3/8 1-1/2 1-5/8	M33	4,400	148,370	660	4.65	118	4.84	123	7.56	192	17	7.7	9.3	4.2
		M36						4.96	126	7.80	198				
		M39						5.12	130	8.03	204				
		M42						5.24	133	8.31	211				
		M42						5.20	132	8.35	212				
TSR+ 4	1-1/2 1-5/8 1-3/4 1-7/8 2	M39	6,670	224,810	1,000	5.55	141	5.31	135	8.58	218	26.5	12	13.4	6.1
		M42						5.47	139	8.86	225				
		M45						5.59	142	9.09	231				
		M48						5.71	145	9.09	231				
		M48						5.83	148	9.76	248				
		M56						6.06	154	10.16	258				
TSR+ 5	2 2-1/4 2-1/2 2-3/4	M60	10,000	337,210	1,500	6.93	176	6.34	161	10.31	262	42.8	19.4	21	9.5
		M64						6.34	161	10.75	273				
		M68						6.57	167	11.14	283				
		M72						6.57	167	11.69	297				
		M76						6.73	171	12.13	308				
TSR+ 6	2-3/4 3 3-1/4 3-1/2	M80	16,670	562,020	2,500	8.62	219	7.09	180	12.28	312	76	34.5	32.4	14.7
		M85						7.09	180	12.72	323				
		M90						7.32	186	13.15	334				
		M90						7.32	186	13.43	341				
		M95						7.32	186	13.62	346				
TSR+ 7	3-1/2 3-3/4 4	M95	21,340	719,390	3,200	9.92	252	7.56	192	14.02	356	103.6	47	42.8	19.4
		M100						7.56	192	14.02	356				
		M100						7.83	199	14.02	356				
		M100						7.83	199	14.02	356				

*TSR+ 0 is not an auto return tensioner.

HYTORC owns all content, copyrights, trademarks and patents in this document. © 2021 HYTORC. Any unauthorized use or distribution of any material from this document is strictly prohibited.

